



### Features

- Huge 4,100 litres per minute flow with 6 inch suction and discharge multi-position ports
- Max head 30 metres
- Self priming from a depth of 7.6m
- Reliable, low maintenance, 29HP Deutz air cooled, two cylinder diesel engine with electric start
- Built in safety shutdown for low oil pressure , oil temperature and V-belt failure
- Oil lubricated silicon/tungsten carbide seals standard with sight glass
- Easy removable, cast iron dual passage volute
- Abrasion resistant cast ductile iron, open/multi-vane impeller
- Easy clean-out port can be removed in seconds
- Heavy duty skid with lifting bar, site trailer option also available
- Solid state control box shock mounted in water resistant housing, includes hourmeter, ammeter, tachometer and alternator failure light
- 60 litre fuel tank incorporated in base of skid
- Weighs 707 kg (dry weight)
- Strainer included to prevent entry of oversized solids
- Bearing and mechanical seal sight glasses
- All pump hardware is corrosion resistant and all interior water passages are obstruction free
- Comes complete with Camlock couplings (male)

### Product Description:

Engineered to meet the requirements of professional contractors, rugged and dependable, these diesel powered trash pumps are ideal for de-watering applications with high solid content.

### Applications:

- De-watering
- Tailing dam pump out
- Public works
- Slurry pumping

### Benefits

- Fast de-watering for even large scale jobs
- Makes it ideal for de-watering duties even over distance
- Quick and easy to set up pump ready for work
- Loads of power, readily available parts and service
- Protection for both the operator and the pump
- Extended seal life, cuts maintenance costs
- For quick priming, minimal clogging and long life.
- Abrasion resistant and capable of passing solids up to 2" in diameter
- Blockages can be cleared without removing connected pipes and without special tools
- Simplifies transportation on site
- Protection in dusty ,wet environments, convenient operator preventative maintenance
- Running time of approx. 7 hours
- Pumps are balanced and can be safely craned
- Prevents clogging and subsequent maintenance
- Enables quick checks to ensure lubricant level correct
- Extends pump life
- Easy hose attachment



Model Numbers: **MQ62TDD**

**Construction:**

- Front case            30 grey iron
- Impeller             SG cast iron
- Volute                SG cast iron
- Back plate          30 grey iron
- Mechanical seal    Oil lubricated silicon/  
tungsten carbide
- Outlet                30 grey iron
- Casing bolts        high tensile steel
- Yoke bolts          high tensile steel
- Check valve        moulded neoprene with  
steel reinforcement
- Priming & drain  
plugs                steel
- Casing, priming &  
drain plug o ring    rubber compound

**Dimensions:**

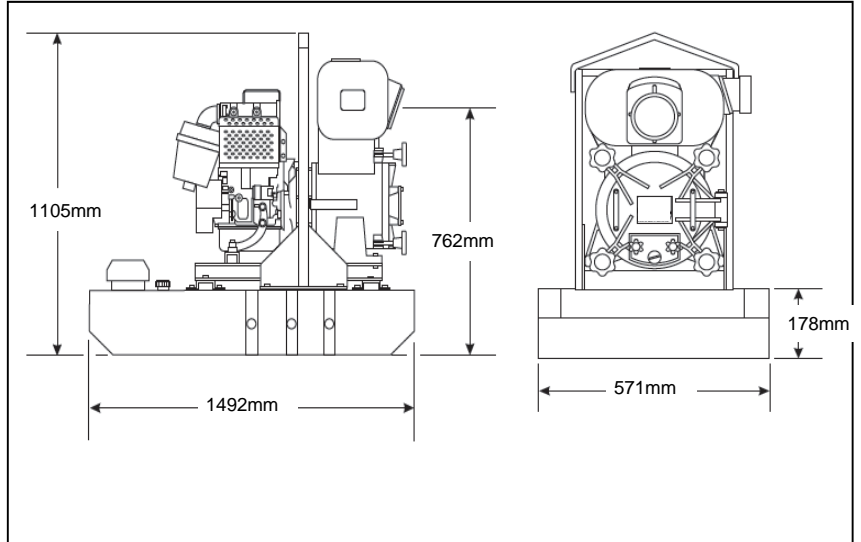

Model	Engine	Type	Max Head (m)	Max Flow (lpm)	Suction Port	Discharge Port	Self primes to (m)	RPM
MQ62TDD	Deutz F2L2011	29HP Diesel Electric Start	30	4,100	6"	6"	7.6	1800

**Performance Curve**

