



FIVE YEAR PUMP END WARRANTY ON ALL AUSSIE QUIK PRIME PUMPS

AUSSIE QUIK PRIME DIESEL DRIVE TRASH PUMPS

Model Numbers: **QP203T** **QP301T**
QP300T **QP40T**



QP301T/L70E

Features

- Five year pump warranty
- Big non clog open style impeller
- High SG impeller volute
- Front mounted clean out port
- Super robust aluminium body
- Full carry frame
- Yanmar or Kubota diesel engines (two year engine warranty)
- Coupling and strainer kit included as standard options
- Honda petrol drive options available (see separate spec sheet)

Specifications

| Model | Engine Brand | Engine model | HP | Max Head (m) | Max Flow (lpm) | Suction port | Discharge port | Self primes to (m) | Max solid size |
|--------|--------------|--------------|------|--------------|----------------|--------------|----------------|--------------------|----------------|
| QP203T | Yanmar | L48 or L48E | 4.8 | 27 | 600 | 2" | 2" | 7.3 | 0.75" |
| | Kubota | AC60 | 6.0 | | | | | | |
| QP300T | Yanmar | L48 or L48E | 4.8 | 27 | 650 | 3" | 3" | 7.4 | 0.75" |
| | Kubota | AC60 | 6.0 | | | | | | |
| QP301T | Yanmar | L70E | 7.0 | 24 | 1200 | 3" | 3" | 7.5 | 1" |
| | Kubota | OC95E | 9.5 | | | | | | |
| QP40T | Yanmar | L100E | 10.0 | 24 | 1800 | 4" | 4" | 7.6 | 1.5" |
| | Kubota | OC95E | 9.5 | | | | | | |

NOTE: Aussie stock codes for QP pumps are determined by using the pump & engine model, for example QP203T/L48E is the 4.8HP Yanmar, electric start version of the QP203T

E in the engine model denotes electric start



Five Year Warranty:

Aussie Quik Prime pumps carry a unique pump end five year warranty. The products are guaranteed to be free of faulty workmanship or material for a period of five years after the date of sale to the end user.

Only top quality genuine brand engines by reputable manufacturers are used. A two year engine manufacturer's warranty applies, administered by the engine manufacturer or it's duly appointed representative. All engines used by Australian Pump Industries are major international brands, serviced and supported not only in Australia and South Pacific but right throughout the world.



Product Description:

Rugged diesel drive trash pumps in 2", 3" and 4" with flows to 1800 litres per minute, heads to 27 metres and suction lift to 7.6 metres. Pumps feature unique mechanical seals that outlast conventional seals by up to six times, a big front mounted cleanout port that enables pumps to be purged of debris without disconnecting pipe work, and high SG, cast iron, non clog style, open impeller and volute system designed to pump solids and resist wear.

Applications:

- Construction site dewatering
- Waste water handling
- Effluent pump out
- Livestock waste water disposal
- Solid laden mine waste pump out

Benefits

Great quality ... use with confidence
Pumps solids in suspension
Resists wear and abrasion
Makes pump chamber clearance easy, no dismantling of pump body or pipe work
Corrosion resistant, long life
Protects pump, facilitates transport on site
Tried and proven with established service networks throughout the world
Convenience and cost savings

Due to our program of continuous product development the manufacturer reserves the right to alter specifications without notice.



FIVE YEAR PUMP END WARRANTY ON ALL AUSSIE QUIK PRIME PUMPS

AUSSIE QUIK PRIME DIESEL DRIVE TRASH PUMPS

Model Numbers: **QP203T** **QP301T**
QP300T **QP40T**

Construction:

| | |
|-------------------------------------|------------------------|
| Front case | Marine grade aluminium |
| Volute | Marine grade aluminium |
| Back plate | Marine grade aluminium |
| Mechanical seal | Carbon/ceramic |
| Outlet | Marine grade aluminium |
| Casing bolts | Zinc plated steel |
| Check valve | Nitrile rubber |
| Priming & drain plugs | Polycarbonate |
| Casing, priming & drain plug orings | Nitrile rubber |
| Finish | Brushed aluminium |
| Impeller | Cast iron, open type |

Dimensions:

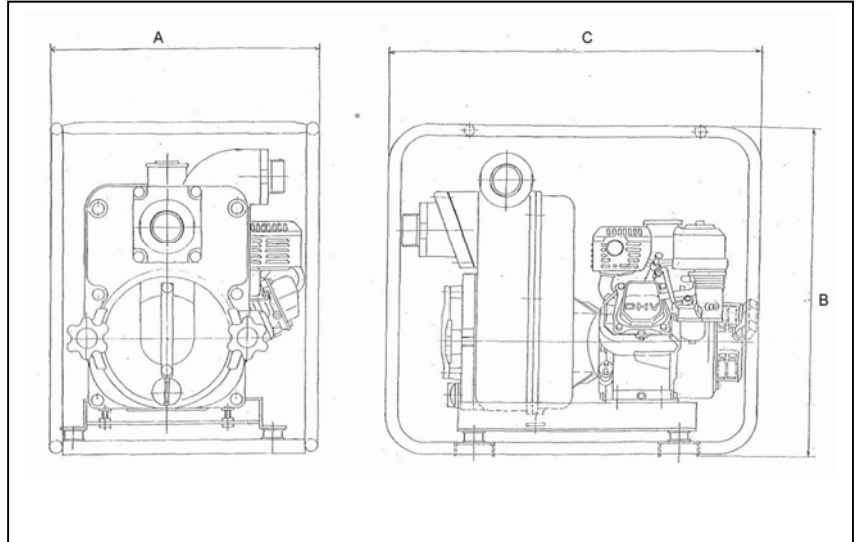

Standard Accessories:

- Coupling kit and strainer
- Full frame

Optional Accessories:

- Heavy duty suction hose
- Medium pressure lay flat delivery hose
- Full galvanised roll frame provided as standard equipment on all diesel engine drive versions or available for corrosive or extreme applications
- Electric start options
- Camlock couplings
- Hydraulic drive option

| Model | Engine | A Width (mm) | B Height (mm) | C Length (mm) | Weight (kg) |
|--------|--------|--------------|---------------|---------------|-------------|
| QP203T | L48 | 470 | 575 | 660 | 65 |
| QP300T | L48 | 470 | 575 | 660 | 65 |
| QP301T | L70 | 493 | 638 | 656 | 78 |
| QP40T | L100 | 602 | 725 | 691 | 115 |



YANMAR

QP203T L48
(shown without 2" reducing nipple)

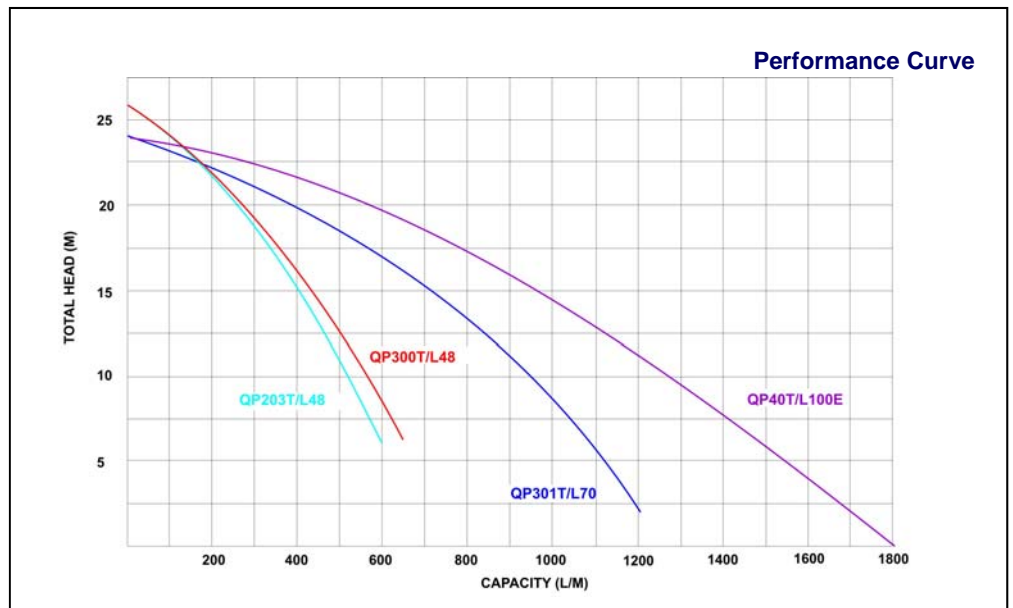

Performance data and curves are to be taken as a guide only



FIVE YEAR PUMP END WARRANTY ON ALL AUSSIE QUIK PRIME PUMPS

AUSSIE QUIK PRIME DIESEL DRIVE TRASH PUMPS

Model Numbers: **QP203T** **QP301T**
QP300T **QP40T**

Aussie MINE BOSS TRASH PUMPS

Applications

- De-watering duties
- Flood mitigation
- Tailing dam pump out
- Public works
- Sewage transfer

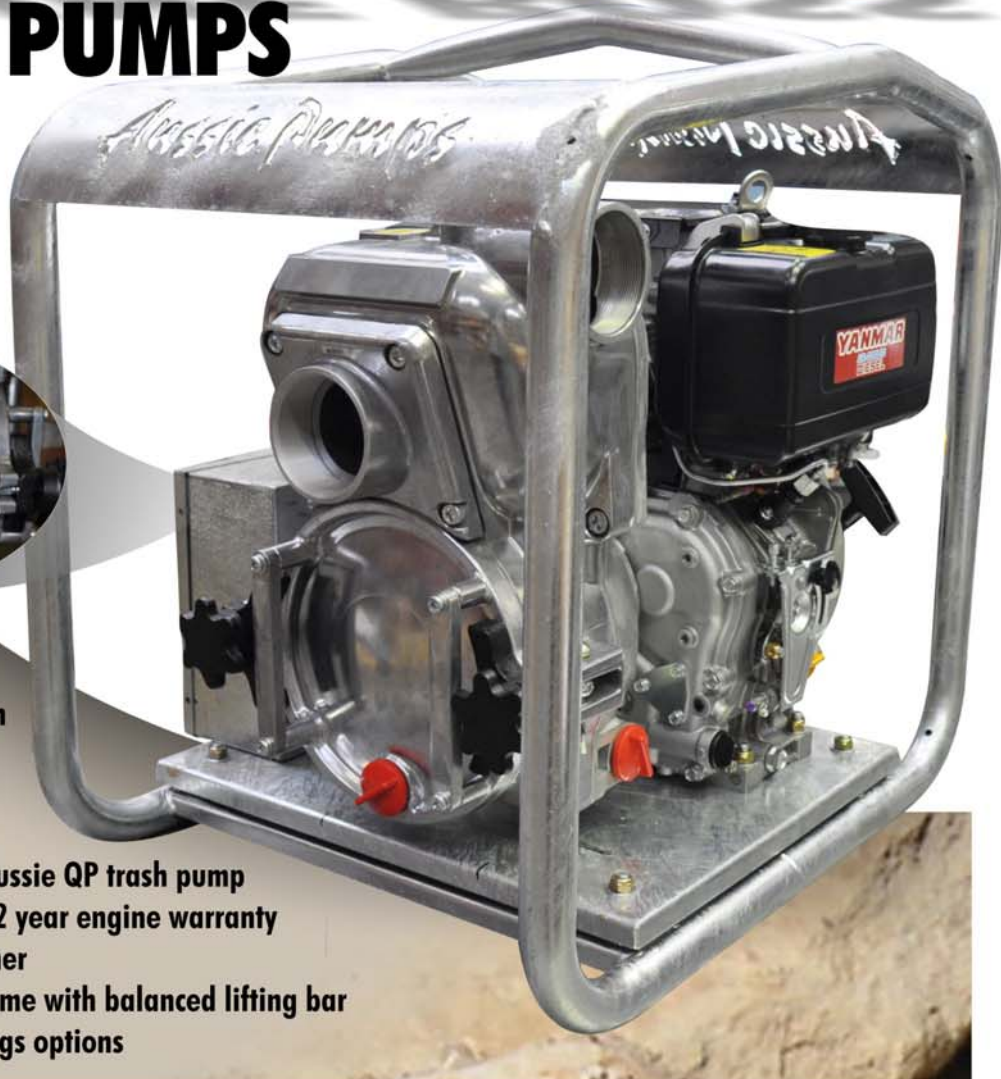

- Dry cell battery
- Emergency stop
- Lockable battery isolation
- 2", 3" & 4" heavy duty Aussie QP trash pump
- Yanmar diesel engine ... 2 year engine warranty
- Integrated fire extinguisher
- Super robust gal steel frame with balanced lifting bar
- Bauer or camlock couplings options

2" ...QP203T/L48EMS2
 Max head 27m, Flows to 600 lpm
 4.8HP Yanmar diesel engine with electric start

3" ...QP301T/L100EMS2
 Max head 30m, Flows to 1200 lpm
 10HP Yanmar diesel engine with electric start

4" ...QP40T/L100EMS2
 Max head 24m, Flows to 1800 lpm
 10HP Yanmar diesel engine with electric start

