



FIVE YEAR PUMP END WARRANTY ON ALL AUSSIE QUIK PRIME PUMPS

AUSSIE QUIK PRIME TRASH PUMPS

Model Numbers: **QP203T**
QP300T
QP301T
QP40T



Product Description:

Rugged trash pumps in 2", 3" and 4" with flows to 1800 litres per minute, heads to 27 metres and suction lift to 7.6 metres. Pumps feature unique mechanical seals that outlast conventional seals by up to six times, a big front mounted cleanout port that enables pumps to be purged of debris without disconnecting pipe work, and high SG, cast iron, non clog style, open impeller and volute system designed to pump solids and resist wear.

Applications:

- Construction site dewatering
- Waste water handling
- Effluent pump out
- Livestock waste water disposal
- Solid laden mine waste pump out

Features

- Five year pump warranty
- Big non clog open style impeller
- High SG impeller volute
- Front mounted clean out port
- Super robust aluminium body
- Full carry frame
- Genuine Honda engines used with all models with oil alert and low oil protection
- Coupling and strainer kit included as standard options
- Diesel drive options with Yanmar or Kubota engines (see separate spec sheet)

Benefits

- Great quality ... use with confidence
- Pumps solids in suspension
- Resists wear and abrasion
- Makes pump chamber clearance easy, no dismantling of pump body or pipe work
- Corrosion resistant, long life
- Protects pump, facilitates transport on site
- Tried and proven with established service networks throughout the world
- Convenience and cost savings
- Economy and longevity

Specifications

Model	Engine	Type	Engine model	HP	Max Head (m)	Max Flow (lpm)	Suction port	Discharge port	Self primes to (m)	Max solid size
QP203T	Honda	4 Stroke	Petrol GX160	5.5	27	600	2"	2"	7.3	0.75"
QP300T	Honda	4 Stroke	Petrol GX160 or GX200E	5.5, 6.5	27	650	3"	3"	7.4	0.75"
QP301T	Honda	4 Stroke	Petrol GX240 or GX270E	8, 9	24	1200	3"	3"	7.5	1"
QP40T	Honda	4 Stroke	Petrol GX390E	13	24	1800	4"	4"	7.6	1.5"

Five Year Warranty:



Aussie Quik Prime pumps carry a unique pump end five year warranty. The products are guaranteed to be free of faulty workmanship or material for a period of five years after the date of sale to the end user.

Only top quality genuine brand engines by reputable Japanese manufacturers are used. A two year engine manufacturer's warranty applies, administered by the engine manufacturer or it's duly appointed representative. All engines used by Australian Pump Industries are major international brands, serviced and supported not only in Australia and South Pacific but right throughout the world.



Due to our program of continuous product development the manufacturer reserves the right to alter specifications without notice.



FIVE YEAR PUMP END WARRANTY ON ALL AUSSIE QUIK PRIME PUMPS

AUSSIE QUIK PRIME TRASH PUMPS

Model Numbers: **QP203T** **QP300T** **QP301T** **QP40T**

Construction:

Front case	Marine grade aluminium
Volute	Marine grade aluminium
Back plate	Marine grade aluminium
Mechanical seal	Carbon/ceramic
Outlet	Marine grade aluminium
Casing bolts	Zinc plated steel
Check valve	Nitrile rubber
Priming & drain plugs	Polycarbonate
Casing, priming & drain plug orings	Nitrile rubber
Finish	Brushed aluminium
Impeller	Cast iron, open type

Dimensions:

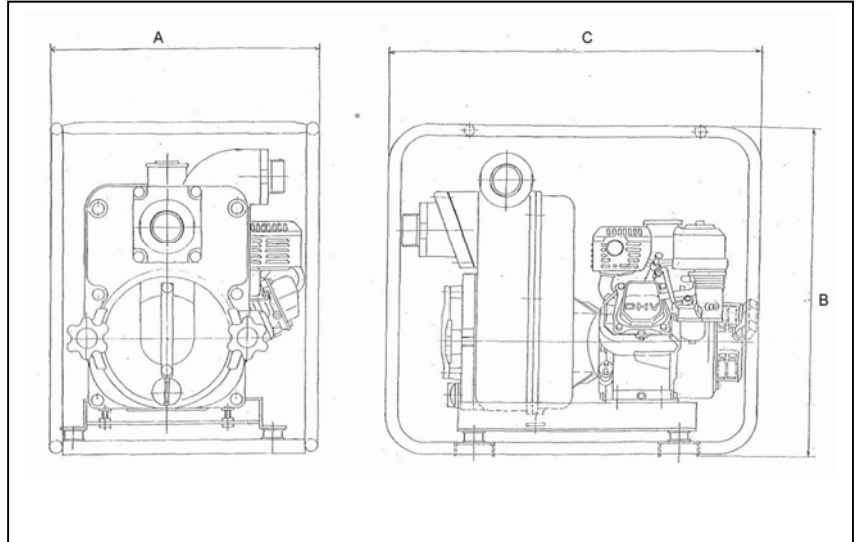

Model	Width A (mm)	Height B (mm)	Length C (mm)	Weight (kg)
QP203T	470	575	660	50
QP300T	470	575	660	50
QP301T	493	638	656	62
QP40T	602	725	691	90

Standard Accessories:

- Coupling kit and strainer
- Full frame

Optional Accessories:

- Heavy duty suction hose
- Medium pressure lay flat delivery hose
- Yanmar, Robin or Kubota air cooled diesel engine drive available
- Full galvanised roll frame provided as standard equipment on all diesel engine drive versions or available for corrosive or extreme applications
- Electric start options
- Camlock couplings
- Hydraulic drive option



QP301T/GX240



QP40T/GX390

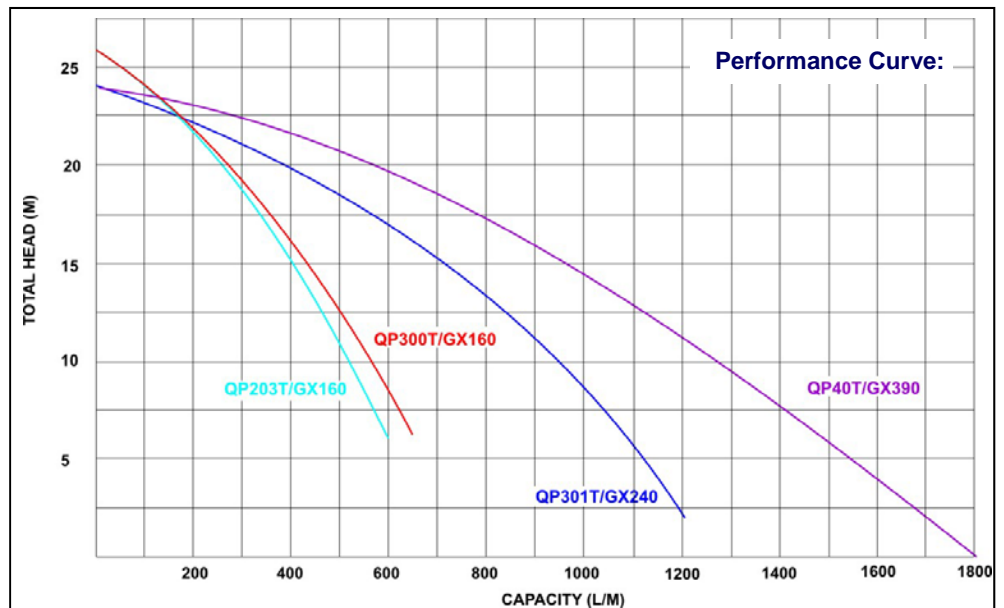

Specifications subject to change as part of ongoing product developments