



**FIVE YEAR PUMP END WARRANTY ON ALL AUSSIE QUIK PRIME PUMPS**

**AUSSIE QUIK PRIME DIESEL DRIVE TRANSFER PUMPS**

Model Numbers: **QP207**      **QP3310**  
**QP209**      **QP402**  
**QP303**      **QP602**



QP402/L100

Aussie diesel powered gushers (transfer pumps) are available in a range of sizes from 2" to 6" inlet/outlet. They are designed to be ultra reliable, economic and have applications in the transfer of high volumes of liquid at relatively low pressures.

Pumps in the range offer flows of up to 2600 litres per minute, (QP602) with heads of up to 30 metres.

Aussie gushers feature big open cast iron impellers capable of pumping some solids in suspension. They are driven by top quality diesel engines from recognised manufacturers with large service networks and are backed by a two year engine manufacturer warranty.

**Applications:**

- High volume water transfer
- Fast fill tanker applications
- Flood irrigation
- Construction site dewatering

**Benefits**

- » Great quality ... use with confidence
- » Ready to pump in minimum amount of time
- » Passes small solids in suspension, long trouble free wear life
- » Easily replaced if thread damaged, easy to service check valve without dismantling pump
- » Protects pump, facilitates transport on site
- » Tried and proven with established service networks throughout the world
- » Transfers more water per litre of fuel
- » Resists corrosion, provides long life
- » Permits pumping of diesel fuel or some ag chemicals
- » Lighter option, makes it easier to carry
- » No separate engine ... cuts service costs
- » Easy to start, no effort required

**Features**

- Five year pump warranty
- Fast self priming from 8m
- Cast iron open impeller
- Replaceable suction port (except QP207)
- Full roll frame with anti vibration mounts standard
- Economical & reliable diesel engines from Yanmar, Robin & Kubota (2 year engine warranty on Yanmar & Kubota engines)
- Exceptional efficiencies
- Pump body components made from high grade marine aluminium
- Optional Viton seal kit
- Petrol engine drive versions
- Hydraulic drive option
- Electric start options (denoted with an E at the end of the engine model)

Model	Yanmar Option		Kubota Option		Robin Option		Max Head	Max Flow	Suction port	Discharge port	Self primes to (m)
	Model	HP	Model	HP	Model	HP	(m)	(lpm)			
QP207	L48	4.8	-	-	-	-	30	600	2"	2"	7.2
QP209	L48	4.8	AC60	6	-	-	28	700	2"	2"	7.6
QP303	L48 L70	4.8 7	AC60 OC95E	6 9.5	-	-	30	1050	3"	3"	7.6
QP3310	L70 L100E	7 10	OC60E OC95E	6 9.5	-	-	30	1300	3"	3"	7.6
QP402	L70 L100E	7 10	OC60E OC95E	6 9.5	DY27	5.4	30 30	1450 1600	4"	4"	7.6
QP602	L100E	10	-	-	-	-	18	2600	6"	6"	7.4

NOTE: Aussie stock codes for QP pumps are determined by using the pump & engine model, for example QP303/L48E is the 4.8HP Yanmar, electric start version of the QP303



**Five Year Warranty:**

Aussie Quik Prime pumps carry a unique pump end five year warranty. The products are guaranteed to be free of faulty workmanship or material for a period of five years after the date of sale to the end user.

Only top quality genuine brand engines by reputable manufacturers are used. A two year engine manufacturer's warranty applies, administered by the engine manufacturer or it's duly appointed representative. All engines used by Australian Pump Industries are major international brands, serviced and supported not only in Australia and South Pacific but right throughout the world.

Due to our program of continuous product development the manufacturer reserves the right to alter specifications without notice.





**FIVE YEAR PUMP END WARRANTY ON ALL AUSSIE QUIK PRIME PUMPS**

**AUSSIE QUIK PRIME DIESEL DRIVE TRANSFER PUMPS**

Model Numbers: **QP207** **QP3310**  
**QP209** **QP402**  
**QP303** **QP602**

**Construction:**

Front case	Marine grade aluminium
Volute	Marine grade aluminium
Back plate	Marine grade aluminium
Mechanical seal	Carbon/ceramic
Outlet	Marine grade aluminium
Casing bolts	Zinc plated steel
Check valve	Nitrile rubber
Priming & drain plugs	Polycarbonate
Casing, priming & drain plug orings	Nitrile rubber
Finish	Brushed aluminium
Impeller	Cast Iron

**Dimensions:**

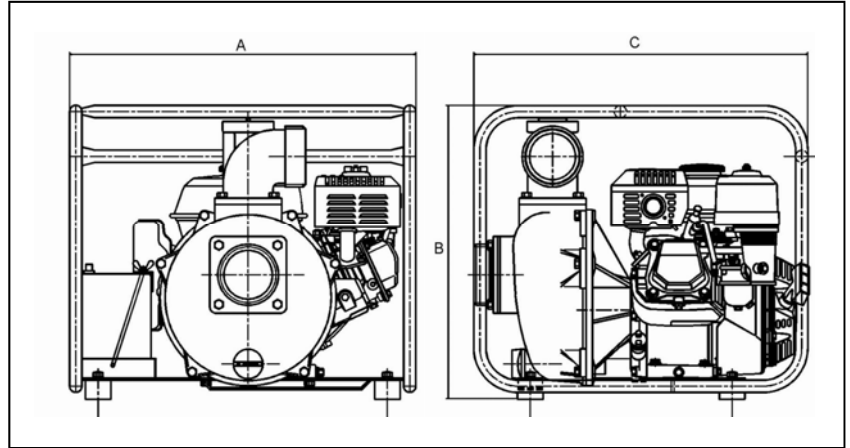

Model	Engine	A Width (mm)	B Height (mm)	C Length (mm)	Weight (kg)
QP207, QP209, QP303	L48	445	510	550	58
QP303, QP310, QP402	L70	560	680	760	83
QP3310, QP402	L100	560	680	760	98
QP602	L100	700	750	950	160



QP303/L48E

QP3110/L100E

QP402/OC95



QP602/L100E

**Standard Accessories:**

- Coupling kit and strainer
- Heavy duty roll frame, 2" through to 6" sizes

**Optional Accessories:**

- Heavy duty suction hose, 2" through to 6"
- Medium pressure lay flat delivery hose 1 1/2" to 6"
- Diesel compatible fuel transfer hoses
- Hydraulic drive option

**Performance Curves**

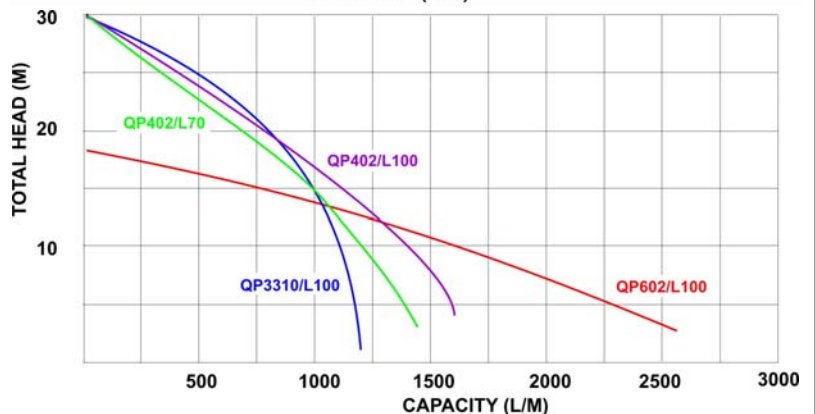
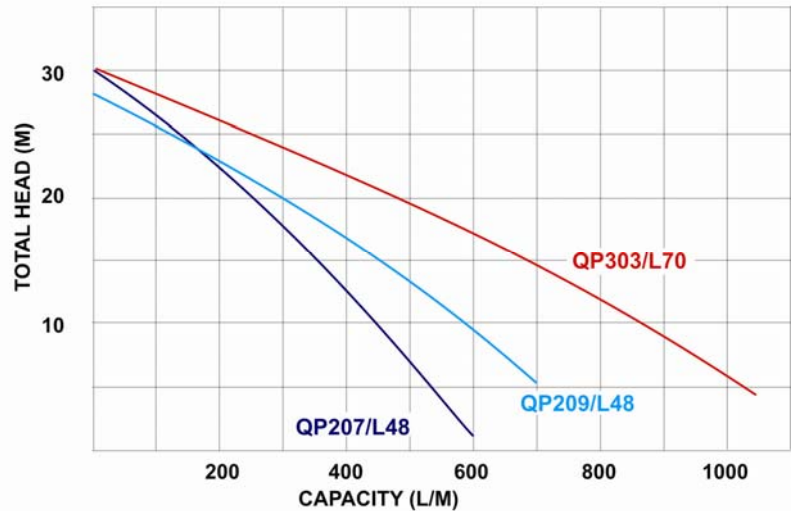

Performance details and curves to be taken as a guide only