

Model Numbers: **QP207** **QP310**
QP209 **QP402**
QP303 **QP602**

FIVE YEAR PUMP END WARRANTY ON ALL AUSSIE QUIK PRIME PUMPS



Features

- Five year pump warranty
- Fast self priming from 8m
- Cast iron open impeller
- Replaceable flanged suction port (except QP207)
- Full roll frame with anti vibration mounts standard (except QP207/GX160NF)
- Genuine Honda engines used with all models
- Exceptional efficiencies
- Pump body components made from high grade marine aluminium
- Optional Viton seal kit
- Optional diesel engine drive versions
- Hydraulic drive option
- Electric start (denoted with a E at the end of the engine model) 6.5HP, 8HP, 9HP and 13 HP models

Product Description:

Aussie gushers (transfer pumps) are available in a range of sizes from 2" to 6" inlet/outlet. They are designed to be ultra reliable, and have applications in the transfer of high volumes of liquid at relatively low pressures.

Pumps in the range offer flows of up to 2900 litres per minute, (QP602) with heads of up to 33 metres.

Aussie gushers feature big open cast iron impellers capable of pumping some solids in suspension. They are driven by top quality four stroke Honda petrol engines with oil alert, low oil shutdown, and cast iron sleeves for long trouble free life. Only genuine Honda engines are used, backed by a 3 year Honda GX engine warranty.

Applications:

- High volume water transfer
- Fast fill tanker applications
- Flood irrigation
- Construction site dewatering

Benefits

- » Great quality ... use with confidence
- » Ready to pump in minimum amount of time
- » Pass small solids in suspension, long trouble free wear life
- » Easily replaced if thread damaged, easy to service check valve without dismantling pump
- » Protects pump, facilitates transport on site
- » Tried and proven with established service networks throughout the world
- » Transfers more water per litre of fuel
- » Resists corrosion, provides long life
- » Permits pumping of diesel fuel or some ag chemicals
- » Fuel economy, engine longevity
- » No separate engine ... cuts service costs
- » Easy to start, no effort required

Model	Engine	Type	Engine model	HP	Max Head (m)	Max Flow (lpm)	Suction port	Discharge port	Self primes to (m)	Weight (kg)	
QP207	Honda	4 Stroke	Petrol	GX120	4	30	600	2"	2"	7.2	25
QP209*	Honda	4 Stroke	Petrol	GX160 or GX200(E)	5.5, 6.5	33	800	2"	2"	7.6	28
QP303*	Honda	4 Stroke	Petrol	GX160 or GX200(E)	5.5, 6.5	32	1000	3"	3"	7.6	31
QP310	Honda	4 Stroke	Petrol	GX240 or GX390(E)	8,13	30	1300	3"	3"	7.6	79
QP402	Honda	4 Stroke	Petrol	GX240 or GX390(E)	8,13	28	1800	4"	4"	7.6	79
QP602#	Honda	4 Stroke	Petrol	GX390E	13	23	2900	6"	6"	7.4	140

* Larger engine sizes available for this model

Long range fuel tank (18L) option available

NOTE: Aussie stock codes for QP pumps are determined by using the pump & engine model, for example QP303/GX200E is the 6.5HP Honda, electric start version of the QP303



Five Year Warranty:

Aussie Quik Prime pumps carry a unique pump end five year warranty. The products are guaranteed to be free of faulty workmanship or material for a period of five years after the date of sale to the end user.

Only top quality genuine brand engines by reputable manufacturers are used. A 3 year engine manufacturer's warranty applies to Honda GX engines, administered by Honda Australia or it's duly appointed representative. All engines used by Australian Pump Industries are major international brands, serviced and supported not only in Australia and South Pacific

Due to our program of continuous product development the manufacturer reserves the right to alter specifications without notice.



Model Numbers: **QP207** **QP310**
QP209 **QP402**
QP303 **QP602**

FIVE YEAR PUMP END WARRANTY ON ALL AUSSIE QUIK PRIME PUMPS

Construction:

Front case	Marine grade aluminium
Volute	Marine grade aluminium
Back plate	Marine grade aluminium
Mechanical seal	Carbon/ceramic
Outlet	Marine grade aluminium
Casing bolts	Zinc plated steel
Check valve	Nitrile rubber
Priming & drain plugs	Polycarbonate
Casing, priming & drain plug orings	Nitrile rubber
Finish	Brushed aluminium
Impeller	Cast iron

Dimensions:

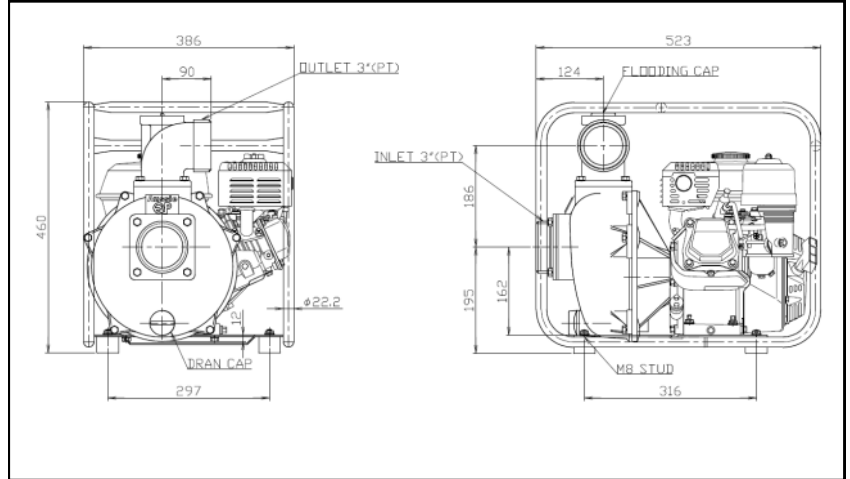

Model	A (mm)	B (mm)	C (mm)	Weight (kg)
QP207/GX120	345	407	455	24
QP209/GX160	386	460	523	30
QP303/GX160	386	460	523	30
QP303/GX200E	542	470	560	35



QP207/GX120



QP209/GX160



QP303/GX160



QP310/GX390E



QP602/GX390E

Performance Curve:

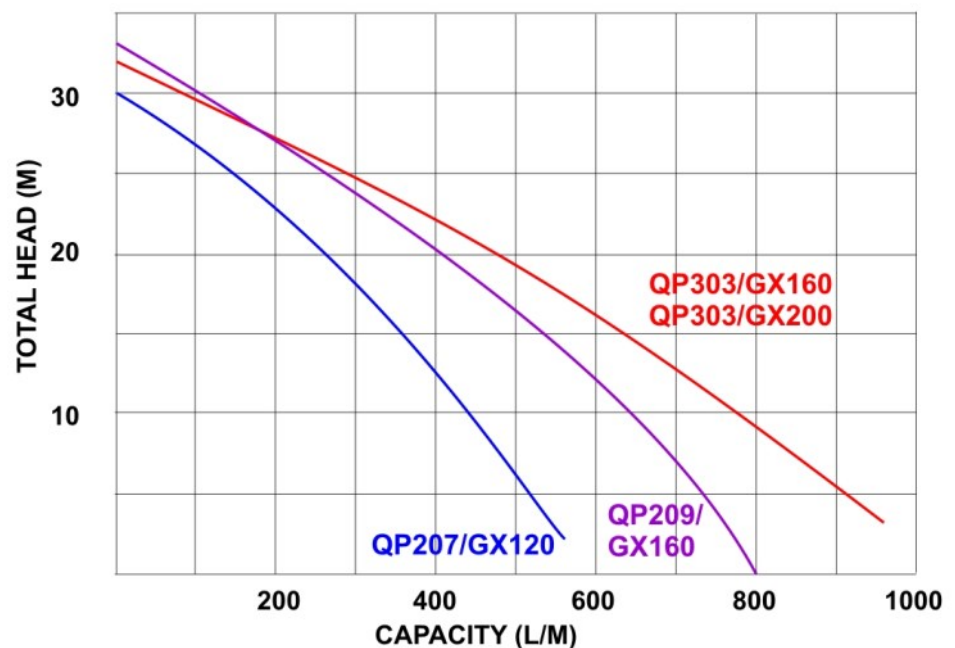

Due to our program of continuous product development the manufacturer reserves the right to alter specifications without notice.

Model Numbers: **QP207** **QP310**
QP209 **QP402**
QP303 **QP602**

FIVE YEAR PUMP END WARRANTY ON ALL AUSSIE QUIK PRIME PUMPS

Model	A (mm)	B (mm)	C (mm)	Weight (kg)
QP310/GX390	500	608	722	79
QP402/GX390 (e/start option)	500 (608)	608 (678)	722 (735)	79
QP602/GX390	680	782	910	140

Dimensions:

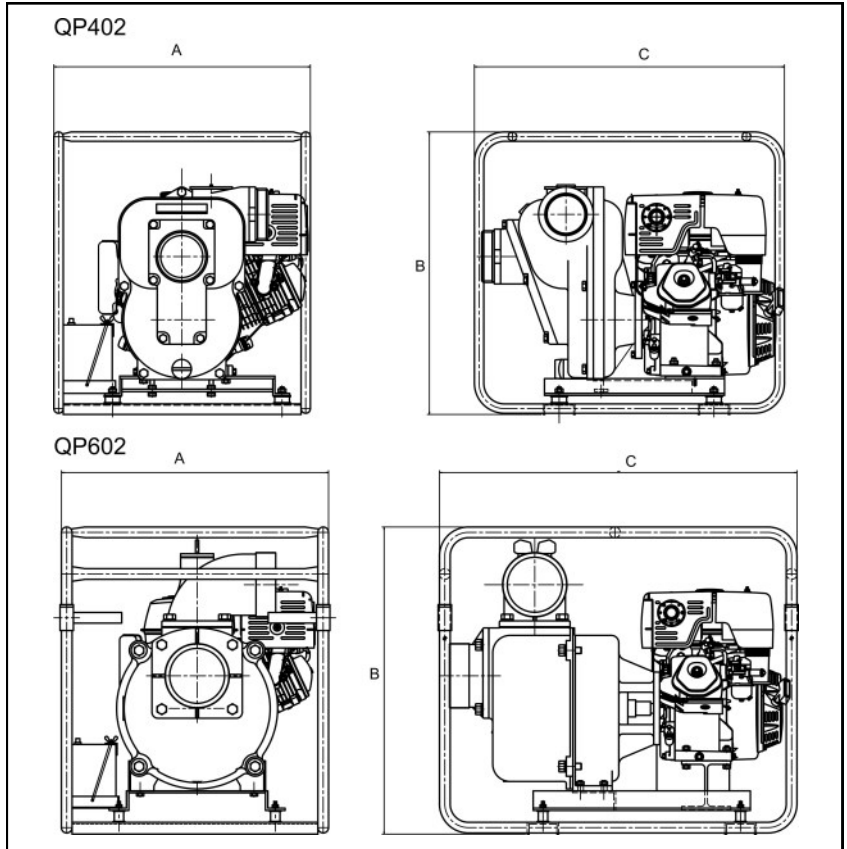

Standard Accessories:

- Coupling kit and strainer
- Heavy duty roll frame, 2" through to 6" sizes

Optional Accessories:

- Heavy duty suction hose, 1½" through to 6"
- Medium pressure lay flat delivery hose 1½" through to 6"
- Diesel compatible fuel transfer hoses
- Yanmar or Kubota air cooled diesel engine drive available with all models 2" through to 6" versions
- Full galvanised roll frame provided as standard equipment on all diesel engine drive versions and suitable for corrosive or extreme applications
- Hydraulic drive option

Performance Curve:

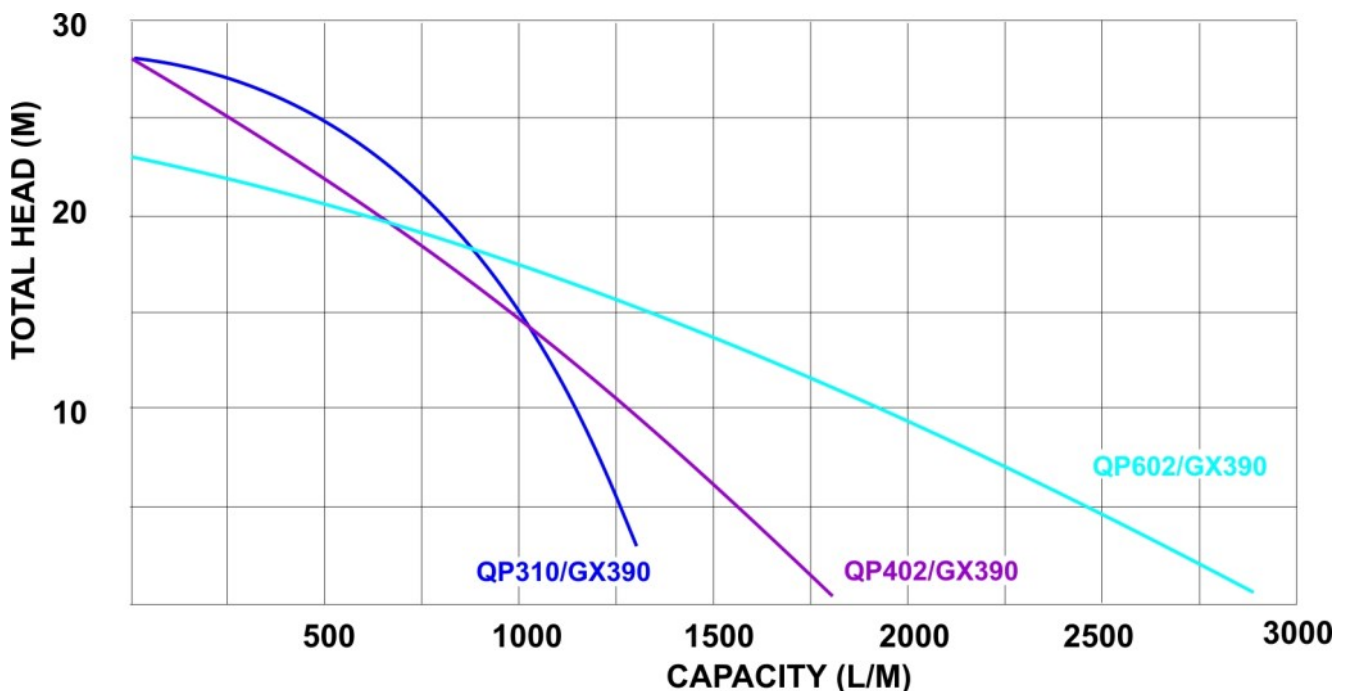

Due to our program of continuous product development the manufacturer reserves the right to alter specifications without notice.