



# "BIG BERTY" BERTOLINI TRIPLEX PUMPS

Model Numbers: **CK3003**  
**C3006**



Model shown:

CK3003

C3006

## Product Description:

Heavy duty slow speed triplex pumps, flows to 42 lpm and pressures to 4300 psi (300 bar).

## Applications:

- Heavy equipment maintenance
- Sewer maintenance
- Fire alarm systems
- Hydrostatic testing

## Features :

- Patented du-dry plunger rod bushing
- Oversized roller bearings
- Double "V" packing self-lubricating sealing system
- Compact, anodised die cast big aluminium crank-case
- Highly polished solid ceramic plungers
- Stainless steel chick valves with separately interchangeable inlet-outlet
- Forged brass head
- Interlocking "self-aligning" connecting rods in superior quality hyper 328T alloy or in bronze

## Benefits:

- Reduces friction for smooth operation
- Designed to endure heavier loads and extended operations
- Maximises seal life
- For high strength and corrosion resistance
- Reduce friction and increase seal life
- Ensures the greatest volumetric efficiency and suction capability
- Ensures chemical resistance
- Guarantees perfect alignment, reducing friction, heat, wear, and noise

Specifications	CK3003	C3006
Diameter	G. 1 1/4	G. 1 1/4
Pressure - Min	-0.2bar -3 psi	-0.2bar -3 psi
Pressure - Max	6 bar 87 psi	6 bar 87 psi
Temperature	60° C. 140° F	60° C. 140° F
Diameter - Out	G. 3/4	(N°2) G. 3/4
Shaft	35mm	35mm
Oil - SAE30 30w	12.8 litre 0.74 USG	2.8 litre 0.74 USG

## Drive System:

- User has the option of high powered electric motor or diesel engine
- Can also be connected to a hydraulic drive



# "BIG BERTY" BERTOLINI TRIPLEX PUMPS

Model Numbers: **CK3003 Series**

## Product Description:

### Bertolini CK3003 Series

Slow speed, high performance triplex pumps, designed for extended life operating at high flows.



Maximum Flows 110 lpm  
 Maximum Pressure 2200 psi (150 bar)  
 Max Speed 1750 rpm  
 Shaft size 35 mm

### Piston Pumps CK3003 Series

Pump Model	Volume (l/min)	Pressure		RPM	Required HP		Weight (kg)	Part Number
		bar	psi		electric	petrol		
<b>CK1224</b>	90	80	1200	900	18.8		52	BCK1224
<b>CK1229</b>	110	80	1200	900	22.8		52	BCK1229
<b>CK1235</b>	132	80	1200	900	22.8		52	BCK1235
3 cylinder ceramic piston pumps with solid shaft diameter, 35mm, for electric motor with hollow shaft and petrol engine 18-22.8hp by flange gearbox.								
<b>CK1519</b>	72	105	1500	1450	19.6		52	BCK1519
<b>CK1525</b>	95	105	1500	1450	26.1		52	BCK1525
<b>CK2216</b>	60	150	2200	1450	17.3		52	BCK2216
<b>CK2220</b>	75	150	2200	1450	22.1		52	BCK2220

3 cylinder ceramic piston pumps with solid shaft diameter, 35mm, for electric motor with hollow shaft and petrol engine 19-26hp by flange

<b>CK1523</b>	87	105	1500	1750	23.3	15	52	BCK1523
<b>CK1526</b>	98	105	1500	1750	27.2	18	52	BCK1526
<b>CK2217</b>	65	150	2200	1750	24.2	24	52	BCK2217
<b>CK2219</b>	72	150	2200	1750	27.3	28	52	BCK2219

3 cylinder ceramic piston pumps with solid shaft diameter, 30mm, for electric motor with hollow shaft and petrol engine 12-18hp by flange gearbox.

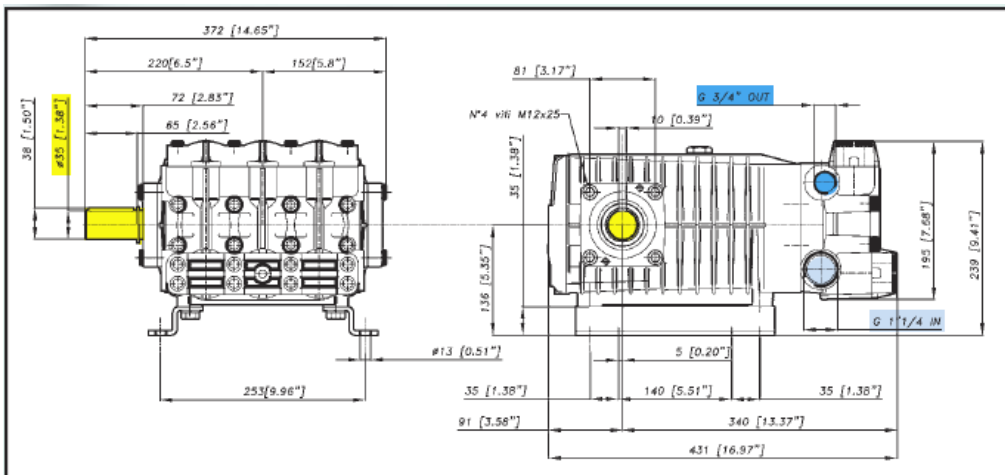



# "BIG BERTY" BERTOLINI TRIPLEX PUMPS

Model Numbers: **C3006**

## Product Description:

### Bertolini C3006 Series

Slow speed, high performance triplex pumps, designed for extended life operating at high flows.

Maximum Flows 220 lpm  
 Maximum Pressure 2200 psi (150 bar)  
 Max Speed 1750 rpm  
 Shaft size 35 mm

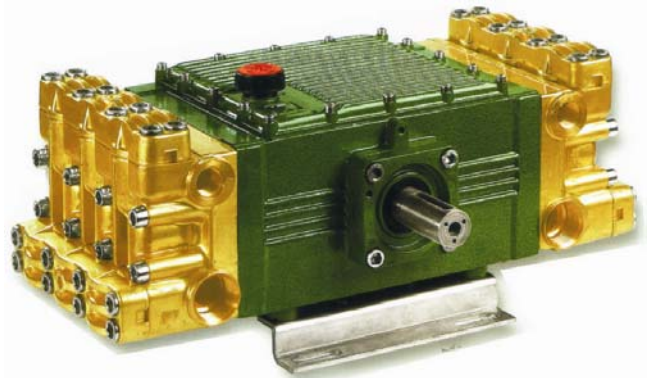

### Piston Pumps C3006 Series

Pump Model	Volume (l/min)	Pressure		RPM	Required HP		Weight (kg)	Part Number
		bar	psi		electric	petrol		
<b>C1248</b>	181	80	1200	900	37.2		79	BC1248
<b>C1258</b>	220	80	1200	900	45.5		79	BC1258
<b>C1538</b>	145	105	1500	1450	40.7		79	BC1538
<b>C2225</b>	100	150	2200	1450	35.8		79	BC2225
<b>C2233</b>	125	150	2200	1450	48.5		79	BC2233

Three cylinder ceramic piston pumps with solid shaft diameter, 35mm, for electric motor with hollow shaft and petrol engine 37-45 hp by flange gearbox.

Three cylinder ceramic piston pumps with solid shaft diameter, 35mm, for electric motor with hollow shaft and petrol engine 40-48 hp by flange gearbox.

<b>C1546</b>	174	105	1500	1750	46.9		79	BC1546
<b>C2230</b>	115	150	2200	1750	42.9		79	BC2230

Three cylinder ceramic piston pumps with solid shaft diameter, 35mm, for electric motor with hollow shaft and petrol engine 42-46 hp by flange gearbox.

