

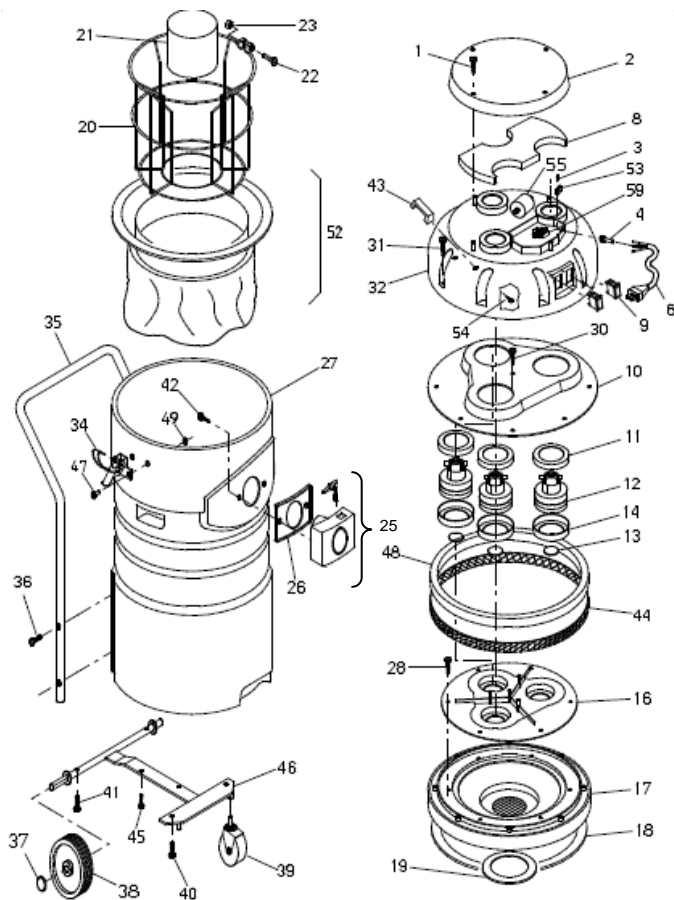

AUSSIE SPARES DIAGRAM & PARTS LIST

AUSSIE VACS: MODEL CLEAN AIR VS73



Position	Part number	Qty Rqd	Description	Retail Price each
1	VA323	4	SCREW	\$1
2	VCZ004C	1	COVER	\$23
3	VVA261	2	SCREW	\$1
4	VPY309	1	BLACK RUBBER FAIRLEAD	\$2
6	VPY358	1	ELECTRIC CABLE	\$63
8	VFO006	1	POLIESTIC MAT	\$20
9	VIN010	3	ON/OFF SWITCH	\$10
10	VDF004	1	DISC	\$30
11	VGR005	3	GASKET	\$5
12	VM0152	3	SUCTION MOTOR (price each)	\$228
13	VTO004	3	MOTOR VALVE	\$2
14	VGR005	3	GASKET	\$5
16	VDF005	1	ADAPTOR LOWER	\$31
17	VCB004	1	CAP BASE D.420	\$40
18	VGO040	1	DOME GASKET	\$11
19	VGO009	1	GASKET-SHUT OFF CAM	\$5
20	VCL005	1	CAGE-SHUT OFF	\$66
21	VGE003	1	CAN-SHUT OFF	\$16
22	VVC218	1	SCREW M5X45	\$1
23	VDD203	1	NUT	\$1
25	VKB506	1	ADAPTOR TANK INTAKE D.40 ASSEMBLY	\$33
26	VGO044	1	GASKET-TAKE INTAKE	\$4
27	VCN103B	1	TANK	\$229
28	VVA322	6	SCREW	\$1
30	VVA326	4	SCREW	\$1
31	VVA326	8	SCREW	\$1
32	VCU009	1	SPHERIC DOME	\$51
34	VCC004	2	GALVANISED HOOK	\$16
35	VMR007	1	BLACK HANDLE FOR CLEANER	\$70
36	VVC227	4	SCREW	\$1
37	VCF009	2	WHEEL PROTECT. CASING	\$4
38	VRT022	2	WHEEL	\$26
39	VRT023	2	CASTER WHEEL	\$16
40	VVE280	2	SCREW	\$1
41	VVC227	2	SCREW	\$1
42	VVA230	2	SCREW	\$1
43	VGG002	2	PLASTIC HANDLE	\$12
44	VFO002	1	ALUMINIUM NET	\$15
45	VVC221	2	SCREW	\$1
46	VBR026	1	TRUCK BASE	\$117
47	VRV031	4	RIVET 4.8 X 16	\$1
48	VFO003	1	POLIESTIC MAT	\$14
49	VRO202	4	WASHER	\$1
52	VKF006	1	FILTER BAG ASSEMBLY	\$90
	VKF056	1	MICROWEB FILTER	\$169
53	VPY252	1	U BOLT	\$1
54	VVA333	4	SCREW	\$1
55	VPY505	1	ANTI NOISE CAPACITOR	\$39
59	VPY182	1	TERMINAL BOARD	\$3

Complete Head

VKE015	Suits VS73	\$1,040
--------	------------	---------





AUSSIE SPARES DIAGRAM & PARTS LIST

AUSSIE VACS: MODEL CLEAN AIR VS73

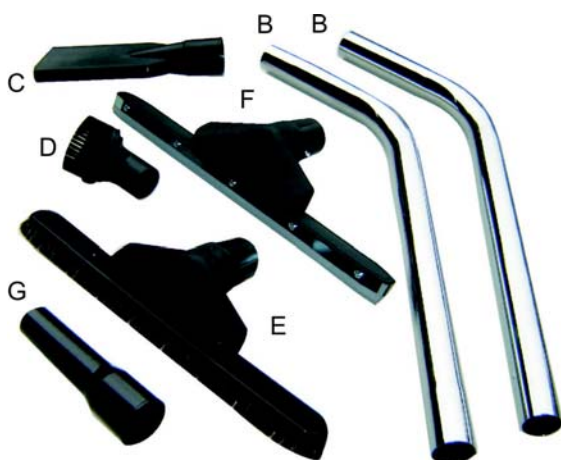

40mm Standard Accessories

		Retail Price	
VAK40MM	Complete kit	\$332	
VHOSE38MMX3	3 metre flexible crush proof hose	\$83	
B	VHH012M VHH012F	2 piece chrome wand assembly including handle (male or female)	\$35 each
C	VLL002N	Crevice tool	\$14
D	VZZ061	Round brush	\$23
E	VKS011	Hard floor brush with swivel (length 420mm)	\$82
F	VKS013	Squeegee with swivel (length 420mm)	\$90
G	VAD001	Accessory adaptor to suit round brush	\$14

Optional 40mm Accessories

VKS012	Aluminium carpet brush with swivel	\$92	
H	VKA011	Outrigger (650mm) with mounting bracket	\$733
VKR001	Hard floor brushes to suit outrigger (two needed for each outrigger) (set of two)	\$67	
VHOSE	Extension hose (per metre)	\$29	
VEE005N	38mm hose cuff (hose to wand fitting)	\$20	
VEE004N	38mm hose tail (hose to tank fitting)	\$17	
V69052	38mm hose jointer	\$24	
VLA013	Rubber squeegee to suit VKS013 (2 required)	\$26	

Paper Bags

V44715	Suits VC44, VS61, VS62, VS73, VS83/3 (1 only -22 litre capacity)	\$20
VSF802	Suits VC44, VS61, VS72, VS73, VS83/3 (1 only -40 litre capacity)	\$29

Filters

VKF006	3 micron, suits VS61/62, VS72/73/83, Drum Vac	\$84
VKF056	Aussie Microweb filter, 99.9% filtration, suits VS61/62, VS72/73 & VS83 Drum vac	\$169

Filter Protectors

VSF015	Nylon filter protector, prevents filter clogging from fine dust, suits VS61/62, VS72/73/83, Drum vac	\$60
--------	--	------

