

# RELIABLE PRODUCTS ... RELIABLE PEOPLE

*Value packed products  
Great Service  
Delivered on time*

Other pumps available from Aussie Pumps...



Aussie QP water transfer & fire pumps



Aussie GMP Industrial pumps



Aussie diaphragm pumps



Australian Pump Industries Pty Ltd  
7 Gladstone Road, Castle Hill NSW 2154  
Ph: (02) 9894 4144 Fax: (02) 9894 4240  
[www.aussiepumps.com.au](http://www.aussiepumps.com.au)  
[info@aussiepumps.com.au](mailto:info@aussiepumps.com.au)

## AUSSIE POLY OWNERS MANUAL



**Aussie Poly Pumps**  
**Engine drive, electric drive,**  
**hydraulic drive, bare shaft**

Revision: #1 (Feb 10)



Australian Pump has developed a reputation for innovation and quality that has led to a rapid market acceptance both in Australia and throughout the world. Aussie Pump products are used in Europe, United States, throughout South East Asia and the Pacific region. Our rapid growth is based on five simple principles.

**Performance**

A genuine dedication to deliver products that out perform and out feature all others, leading to better outcomes for users.

**Quality**

A relentless drive for quality that delivers lower through life costs and improved ecological outcomes

**Value**

A pricing policy that delivers excellent products at fair prices.

**Prompt Delivery**

A commitment to build and deliver on time

**After Market Support**

To provide through life support through well trained, professional and motivated distribution team both in Australia and throughout the World.

	<p><b>SAFETY WARNING</b></p> <p><b>Do not use a pump that is not chemically compatible with the liquid you intend to pump. Serious injury, death or environmental damage could result.</b></p> <p>If uncertain contact your Aussie dealer for the Corrosion<sup>2</sup> Resistance Charts.</p>
--	--

Ref #	Part number	Description	Quantity
13-14	58.0714.11	SHAFT SEAL BUNA N 316SS CARBON CERAMIC	1
13-14	58.0714.12	SHAFT SEAL EPDM 316SS CARBON CERAMIC	1
13-14	58.0714.14	SHAFT SEAL VITON 316SS CARBON CERAMIC	1
15	58.0975.30	IMPELLER HIGH VOLUME 4 VANE 975	1
15	58.0704.30	IMPELLER 4HP 3 VANE 704	1
15	58.0706.30	IMPELLER HIGH HEAD 5 VANE 706	1
16	58.0716.10	SCREW IMPELLER SS	1
17	58.0977.30	VOLUTE HIGH VOLUME (975)	1
17	58.0702.30	VOLUTE HIGH HEAD (706)	1
18	58.0725.10	SCREW SIDE VOLUTE SS	2
19	58.0771.10	SCREW TOP VOLUTE SS	1
20	58.0705.71	CHECK VALVE - BUNA N	1
20	58.0705.72	CHECK VALVE - EPDM	1
20	58.0705.73	CHECK VALVE - VITON	1
21	58.0720.10	SCREW BODY STAINLESS STEEL	10
22	58.1009.71	O-RING DRAIN PLUG BUNA	1
22	58.1009.72	O-RING DRAIN PLUG EPDM	1
22	58.1009.73	O-RING DRAIN PLUG VITON	1
23	58.0723.30	DRAIN PLUG	1
24	58.0722.30B	FILLER PLUG	1
25	58.0765.71	O-RING FILLER PLUG - BUNA	1
25	58.0765.72	O-RING FILLER PLUG - EPDM	1
25	58.0765.73	O-RING FILLER PLUG - VITON	1
27	58.0718.10	KEY 316SS	1
30	58.0778.11	SHIM .006 SS	As req
42	58.0784.30B	FRONT CASING 2"	1
42a	58.0877.30B	FRONT CASING 3"	1
46	58.0882.90	SHAFT SLEEVE	1
56	58.0001	PLASTIC PEDESTAL KIT - CARBON STEEL SHAFT	1
56a	58.0012	PLASTIC PEDESTAL KIT - STAINLESS STEEL SHAFT	1
56b	RKIT097	CAST IRON PEDESTAL KIT - STAINLESS STEEL SHAFT	1
70a	58.1367.40	OPTIONAL DELVERY ELBOW 2" BSP	1
70b	58.1368.40	OPTIONAL DELIVERY ELBOW 3" BSP	1
S2 & S3	58.0014	BUNA N CONVERSION KIT	0
S2 & S3	58.0005	EPDM CONVERSION KIT	0
S2 & S3	58.0017	VITON CONVERSION KIT	0

'S' SERIES 2" & 3" POLY PUMP – SPARE PARTS PRICES

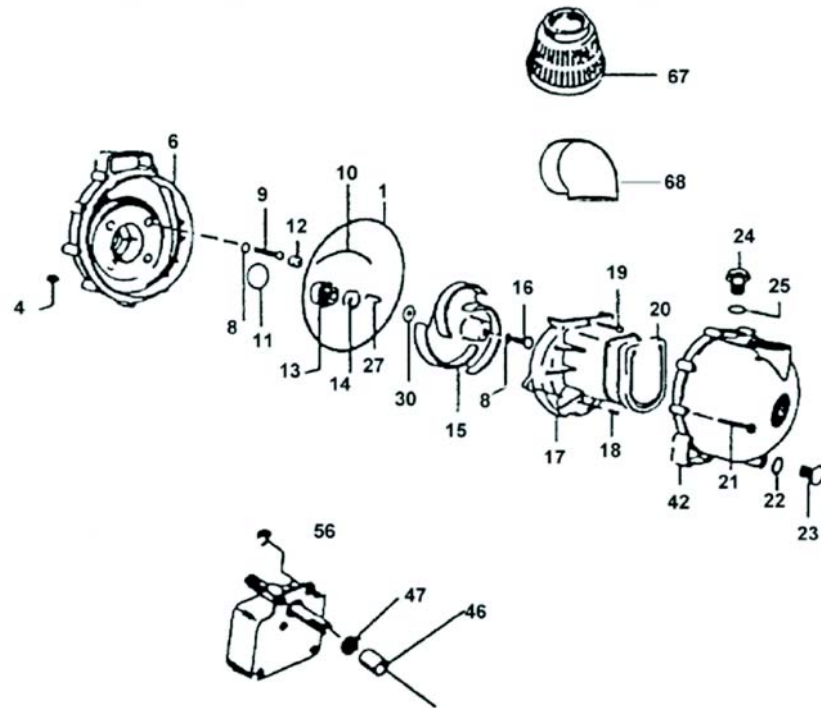

Ref #	Part number	Description	Quantity
4	58.0721.10	NUTS	10
6	58.0703.30	BACK CASING (BRACKET)	1
7	58.0719.71	O-RING BODY BUNA N	1
7	58.0719.72	O-RING BODY EPDM	1
7	58.0719.73	O-RING BODY VITON	1
8	58.0717.71	O-RING SCREW BUNA-N	5
8	58.0717.72	O-RING SCREW EPDM	5
8	58.0717.73	O-RING SCREW VITON	5
9	58.0715.10	SCREW BRACKET 5/16 – 24 X 1.25	4
10	58.0754.71	O-RING SEG BUNA N	1
10	58.0754.72	O-RING SEG EPDM	1
10	58.0754.73	O-RING SEG VITON 1	1
11	58.0976.71	O-RING SHAFT SEAL BUNA N	1
11	58.0976.72	O-RING SHAFT SEAL EPDM	1
11	58.0976.73	O-RING SHAFT SEAL VITON	1
12	58.0750.40	SCREW PLUG	1

Table of Contents ..... 3  
 Product specifications ..... 3  
 Safety ..... 4  
 Start up and installation details ..... 5  
 Warranty terms ..... 6  
 Easy service data ..... 8  
 Troubleshooting ..... 9  
 Exploded view & parts list ..... 10/11

Keep this owner's manual handy so you can refer to it at any time. The Aussie Pump Owner's manual is considered a permanent part of the pump and should remain with it if resold.

The information and specifications included in this publication were valid at the time of printing however, Australian Pump Industries reserves the right to discontinue or change the specifications or design any time without notice and without incurring any obligation.

PRODUCT SPECIFICATIONS

Engine drive	Impeller	Max Flow	Max Head	EPDM	Buna N	Viton*
	2" 706 high head	720	37	RSE2BUL	RSE2BUB	RSE2BUV*
	2" 975 high flow	835	25	RSE2BRL	RSE2BRB	RSE2BRV*
	3" 706 high head	870	37	RSE3BXL	RSE3BXB	RSE3BXV*
	3" 975 high flow	1010	25	RSE3BSL	RSE3BSB	RSE3BSV*

Electric drive	Impeller	Max Flow	Max Head	EPDM	Buna N	Viton*
	2" 706 high head	580	22.5	RSE2BUL	RSE2BUB	RSE2BUV*
	2" 975 high flow	660	16	RSE2BRL	RSE2BRB	RSE2BRV*
	3" 706 high head	700	22.5	RSE3BXL	RSE3BXB	RSE3BXV*
	3" 975 high flow	800	16	RSE3BSL	RSE3BSB	RSE3BSV*

Hydraulic/bare shaft	Impeller	Max Flow	Max Head	EPDM	Buna N	Viton*
	2" 706 high head	720	37	RSE2BUL	RSE2BUB	RSE2BUV*
	2" 975 high flow	835	25	RSE2BRL	RSE2BRB	RSE2BRV*
	3" 706 high head	870	37	RSE3BXL	RSE3BXB	RSE3BXV*
	3" 975 high flow	1010	25	RSE3BSL	RSE3BSB	RSE3BSV*

(Recommendation only - check compatibility chart for specifics)

1. For oil based liquids including diesel fuel, select **BUNA** elastomer option
2. For most ag. chem. liquids select **EPDM** elastomers
3. **Viton** elastomers available. For chemical compatibility check 'Chemical Compatibility Chart'

**SAFETY ALERT**



To get the best out of your Aussie Pump product these important warning notices need to be observed.



Do not refuel engine while operating. Shut engine down before refueling.



Before starting the pump read Pump Operators manual.



Some engine components will get hot during operation. Do not touch engine components while engine is running or immediately after operation. For details check engine operator's manual.

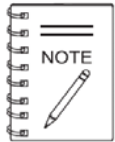

Please note that the pump operator's manual does not include detailed engine data. Check the engine manufacturer's manual, supplied with the product, for further information.



Do not allow children to operate the pump.



No oil is supplied with the engine. Oil must be added in accordance with the engine manufacturer's instructions. (Relevant to four stroke engines only).



Familiarise yourself with the pump's controls with emphasis on how to stop the pump quickly.



Always refuel in a well ventilated area, do not smoke or allow flames or sparks in the refueling area or where gasoline is stored.



Pump must be primed before starting. Fill pump body with liquid. Pump must not be allowed to run without liquid passing through the casing. DO NOT run pump either dry or with insufficient water supply. Pump supply or delivery lines must not be shut off.



Do not over fill the fuel tank, as spilled fuel can ignite if it comes into contact with hot engine parts or sparks. After refueling, make sure tank cap is closed properly and is secure.



Do not use the pump in a gaseous or hazardous environment or near combustible material.



Protect your pump from pressure spikes by installing a by-pass or safety valve if sudden shut off of the water flow is likely to occur.



Do not use the pump in an enclosed area, engine exhaust could build up and cause asphyxiation.

**TROUBLESHOOTING**

Practically all breakdowns can be prevented by proper handling and maintenance inspections, but in the event of an issue check the Troubleshooting information shown below.

PUMP TROUBLESHOOTING		
SYMPTOM	POSSIBLE PROBLEM	SOLUTION
Pump does not take on water.	Not enough priming water in the housing?	Add water.
	Engine speed too low?	Increase throttle.
	Strainer plugged?	Clean strainer
	Suction hose damaged?	Replace or repair hose, and clamps
	Air leak at suction port?	Check that fittings are tight and properly sealed.
	Pump is located too high above water line?	Move pump closer to water.
	Debris collecting in pump housing?	Clean pump housing.
	Too much distance between impeller and volute.	Adjust clearance by adding shims or replace impeller. Min. .010" -Max. .020
	Water leaking out weep hole between pump and engine?	Check condition of mechanical seal and gaskets, between pump end and engine housing.
Suction lift or discharge head too high.	Check hose/pipe installation.	
Pump takes in water, little or no discharge.	Engine speed too low?	Increase throttle speed
	Suction strainer partially plugged?	Clean strainer
	Impeller/volute worn?	Adjust clearance by adding shims or replace impeller/volute
Suction hose leaks at inlet	Fittings/clamps are not sealed properly?	Tighten, replace or add clamp. (Keep extra seals on pump)
	Hose diameter is too large?	Use smaller diameter hose or replace hose
Discharge hose does not stay on coupling.	Pressure too high?	Check pressure, add additional clamp.
	Hose kinked or end blocked?	Check hose.
Impeller does not turn, pump is hard to start.	Impeller jammed or blocked?	Open pump cover and clean dirt and debris from inside housing.
	Impeller and volute binding?	Adjust clearance by removing shim from behind impeller.
	Defective engine?	See Engine Owners Manual.9

**Engine Troubleshooting;** refer to engine manufacturer's manual

**Handy service hints**

1. To maximize pump life, drain pump after use and flush out with clean, fresh water.
2. Read engine manufacturer's owner's manual thoroughly and service as recommended.
3. Store pump in a dry, safe location when not in use.
4. If storing for long periods, drain fuel from engine and tank.
5. Before pumping chemicals check suitability of seals. For oil based liquids including diesel fuel, select BUNA elastomer option. For most ag. chem. liquids select EPDM elastomers. Viton elastomers are also available for corrosive applications. For further information regarding chemical compatibility contact your Aussie dealer.
6. Pumping water containing solids will prematurely wear pump components, and may impact warranty.
7. Ensure that the correct size strainer is installed on the suction hose at all times.

**Service/Installation hints**

**Systems requiring hydrostatic relief valve.**

Fitting a hydrostatic relief valve in any installation should only be carried out by a pump or installation specialist. Such products offer limited hydrostatic relief. It is the responsibility of the installer to ensure that the performance of the valve meets the required application.

**Hydrostatic Shock**



Prevent hydrostatic shock by using thick planking either side of the hose where it crosses roadways.

**Strainer Placement**



Place strainer on bed of rocks or inside an old bucket. Alternatively use a pontoon or float to keep pump strainer clear of debris.

When installing an Aussie self priming pump always remember that the closer the pump is placed to the source of supply the better the performance will be.

To ensure maximum capacity select a site that will permit the shortest and most direct suction piping and smallest vertical lift.

Set the pump on firm and level foundations.

**Connecting the Suction Hose**

Use commercially available hose, hose connector and hose bands. The suction hose must be of reinforced non collapsible construction, suction hose length should not be longer than necessary as the longer the suction hose, the less delivery performance of the pump. Self priming time is also proportional to suction hose length!

Strainer should always be used on the end of the suction hose to keep solids out of the pump.

Check carefully to make sure there are no air leaks in the suction line.

**Connecting the Discharge Hose**

Use a commercially available hose, hose connector and hose bands. A large diameter hose is most efficient.

Long, small diameter hoses will increase friction loss and reduce pump performance and adversely affect performance.

**Priming**

Remove the priming cap at the top of the delivery port. Fill pump body with water and refit priming cap tightly.

Open gate valve on delivery line if fitted.



Never attempt to operate pump without priming first. Extended dry operation will destroy pump seal. If unit has been operated dry, stop the engine immediately, allow the pump to cool before adding priming water.

**Hydraulic Shock**

If the water flow is suddenly terminated by closing a valve, without stopping the pump first, it can cause hydraulic shock. This can travel back to the pump causing serious damage. To prevent pump damage install a by-pass or safety valve.

## WARRANTY TERMS

**Aussie poly pump warranty**

Australian Pump warrants that all Aussie poly pump self priming centrifugal pumps, whether used for domestic or commercial applications, are warranted to be free of faulty workmanship or material for a period of one year from the date of supply to the end user.

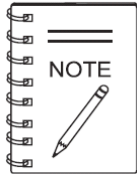

Note:- This warranty is limited to the cost of the product and does not include third party costs including pump installers, plumbers etc. unless expressly authorised by Australian Pump Industries in writing.

**Engine Warranty**

Warranty for engines fitted to Aussie Pump products is the responsibility of the engine manufacturer or his representative. As such, it is subject to the particular manufacturer's stated guarantee, terms and conditions, and operating instructions included with the product.

The warranty is valid only for the original consumer purchaser. Warranty is not automatically transferred if the goods are sold on as second hand items.

**Aussie Pump warranty** does not cover the following:-

1. Normal wear and tear.
2. Damage generated by removal or installation of the product.
3. Unauthorised repair or attempted repair (i.e. not authorised by Australian Pump)
4. Shipping or transit damage
5. Use of non-genuine parts.

**Warranty Claims**

When claiming warranty, consumers must give evidence to the local Aussie Pump service station of date of purchase, model and serial number of the product, and the claimant's name, address and telephone number.

To claim warranty, you will need to provide the following data:-

1. Written confirmation of the nature of your claim.
2. Proof of purchase.
3. Where necessary, full installation data, including installation design drawings where appropriate.
4. The product must be forwarded freight pre-paid to Australian Pump with prior written approval.

Costs generated by a service call from an authorised Aussie Pump service agent will incur a travel, removal and re-installation fee if the service agent is required to judge warranty issues.

In the event that the product is not readily accessible for inspection, warranty service will be denied or suspended pending availability of the whole item.

Warranty will be denied if product is found to have been abused, misused, or improperly installed.

Any unauthorized modification to the equipment will automatically void warranty.