



# AUSSIE SAFE JETTING

## Aussie Cobra Series Drain Cleaning Jetters

DEC 2023

### SAFE OPERATOR INSTRUCTION MANUAL



#### SAFETY NO.1

Before using this Jetter

1. READ THIS MANUAL CAREFULLY
2. VIEW HAND-OVER VIDEO



# Aussie Pumps

REF: ACOBRAMANVER15

# AUSSIE SAFE JETTING

## AUSSIE DRAIN CLEANING JETTER RISK ASSESSMENT



In line with the National Occupational Health & Safety Commission's requirements the data below applies to the Aussie Cobra series of drain cleaning models:

- Aussie Cobra A Class A
- Aussie Python Class B
- Aussie King Cobra Class A
- Aussie King Cobra Class B

Note: Class A Jetters don't require RTO operator certification

Check out Aussie's FREE online Safe Jetting Training Course



### DESCRIPTION:

Engine drive high pressure drain cleaning Jetters designed for both domestic and professional cleaning applications.

### MATERIAL CONSTRUCTION:

Aussie drain cleaning Jetters are mounted on heavy duty trolley mounted frames. They consist of a quality internal combustion petrol or diesel engine driving a triplex style three piston high pressure pump. The machines are supplied with wheels for ease of portability and manoeuvrability. The machines are supplied with hose reels and up to 60 metres of sewer hose to increase operator convenience.

### RISK RANKING METHOD:

Risk is the combination of the likelihood of a specific unwanted event and the potential consequences if it should occur.

### RISK RANKING TABLE:

The consequences (loss outcomes) are combined with the likelihood (of those outcomes) in the risk ranking table to identify the risk rank of each loss event (e.g. a consequence of 'Moderate' with a likelihood of 'Likely' yields a risk rank of 17).

The table yields a risk rank from 1 to 25 for each set of probabilities and consequences. A rank of 25 is the highest magnitude of risk that is a highly likely, very serious event.

A rank of 1 represents the lowest magnitude of risk, an almost impossible very low consequence event.

Controls must be taken to either eliminate or minimise the risk.

Likelihood	Use the matrix to determine the risk	Consequences				
		Insignificant	Minor	Moderate	Major	Catastrophic
Likelihood	Almost certain	High 11	High 16	Extreme 20	Extreme 23	Extreme 25
	Likely	Moderate 7	High 12	High 17	Extreme 21	Extreme 24
	Possible	Low 4	Moderate 8	High 13	Extreme 18	Extreme 22
	Unlikely	Low 2	Low 5	Moderate 9	High 14	Extreme 19
	Rare	Low 1	Low 3	Moderate 6	High 10	High 15



## Risks associated with operating a drain cleaning Jetter ... for use on daily **SAFE WORK METHOD STATEMENT**

Potential Hazard	Risk	Risk Rating	Controls
Entanglement with sewer hose (tripping, falling)	Personal injury of the operator or bystanders	13	<ul style="list-style-type: none"> <li>Minimise trip hazards by using hose reel</li> <li>Ensure firm footing before starting Jetter</li> </ul>
High pressure water jet	Personal injury of the operator or bystanders	13	<ul style="list-style-type: none"> <li><b>Jetting in progress warning</b> notice on Jetter</li> <li><b>Wear eye protection &amp; PPE</b> (Aussie Pro-operator—page 13)</li> <li><b>Use high pressure resistant gloves</b></li> <li><b>Always point</b> jet at area to be cleaned</li> <li><b>Use barriers</b> to keep bystanders away from work area</li> <li><b>Stop jetting</b> if persons enter working area</li> <li><b>Never</b> leave Jetter unattended</li> <li><b>Never</b> point hose at any person or animal</li> <li><b>Never</b> put your hand over the Jetter nozzle when operating</li> <li><b>Stop jetting</b> if a malfunction occurs</li> </ul>
Whipping hose 1. at machine start up 2. as drain hose is withdrawn from drain 3. If coupling fails	Personal injury of the operator or bystanders	13	<ul style="list-style-type: none"> <li><b>When starting Jetter firmly hold end of hose pointing down to the ground</b> (with no nozzle attached)</li> <li><b>Markings on hose</b> indicate distance to end of hose</li> <li><b>Train operator</b></li> <li><b>Use of safety plate</b> over drain entrance</li> <li><b>Connect hose restraint</b> between hose &amp; gun or hose &amp; mini reel</li> </ul>
Suffocation	Fatality is the risk	18	<ul style="list-style-type: none"> <li>Do not operate engine without suitable ventilation</li> <li>Operator training in working in confined spaces</li> </ul>
Manual handling	Personal injury	18	<ul style="list-style-type: none"> <li>Operator’s Manual</li> <li>Staff training</li> <li>Long handled drain cover keys</li> </ul>
High temperature (from engine muffler and other components)	Burns to the operator	11	<ul style="list-style-type: none"> <li>Warning sticker on engine</li> <li>Keep clear of hot engine parts</li> </ul>
Fire or explosion	Serious injury, burns	18	<ul style="list-style-type: none"> <li>Do not operate Jetter in explosive atmosphere</li> <li>Turn off engine &amp; allow engine to cool before refuelling</li> </ul>
Battery exploding if not charged correctly	Acid burns	14	<ul style="list-style-type: none"> <li>Warning sticker on battery</li> <li>Wear eye &amp; face protection when working near battery</li> </ul>
Unsecured machine, moves unattended	Cause of accidents and/or injury	8	<ul style="list-style-type: none"> <li>Use of chocks behind wheels or ute mounting kit</li> </ul>
Noise	Hearing damage	11	<ul style="list-style-type: none"> <li>Use of ear protection</li> </ul>
Dislodged particles in atmosphere	Sight damage	20	<ul style="list-style-type: none"> <li><b>Never clean asbestos</b> with high pressure water</li> <li>Use of eye protection</li> </ul>
Electrocution if water contacts electricity	Personal injury	19	<ul style="list-style-type: none"> <li>Do not aim water jet at electrical equipment</li> </ul>
Slipping	Personal injury	17	<ul style="list-style-type: none"> <li>Use of proper footwear</li> </ul>
Contact with foul water or sewage	Infection, illness from water splashes, ingested water	17	<ul style="list-style-type: none"> <li>Personal protective equipment, i.e. gloves, overalls, boots, eye and/or face protection etc</li> <li>Operator to use good basic hygiene</li> </ul>
Contact with chemical cleaners used to clean drains	Skin contact could result in burns, skin irritation etc. Fumes from some chemicals may lead to respiratory problems	22	<ul style="list-style-type: none"> <li>Chemical cleaners to only be used as a last resort when other methods have failed</li> <li>Areas to be kept well ventilated</li> <li>Staff to follow manufacturers’ instructions at all times for use, storage &amp; disposal</li> <li>Staff to wear the appropriate PPE</li> <li>Respiratory protection when required</li> </ul>

# AUSSIE SAFE JETTING

## CONTENTS

### AUSSIE DRAIN CLEANING JETTER RISK ASSESSMENT

**CHECKLIST ..... 2**

Specifications..... 4

Warranty Coverage ..... 5

**SAFETY PRECAUTIONS ..... 6**

Work Area Safety ... minimise hazards..... 7

**STAY SAFE ..... 7**

    Safety Clothing ..... 7

    Engine Hazards..... 7

    Jetter Warning..... 7

    Wash Down Operation..... 7

    Bacteria Warning..... 7

Accessory Identification ..... 8

Assembly & Preparation for Use ..... 9

Start Up & Operation ..... 9

Operation as a Drain Cleaning Jetter..... 10

Operation of Aussie Viper Mini Reel ..... 11

Emergency Stop Button ..... 11

Operation as a High Pressure Washer..... 12

ASP (Aussie Safety Protection) System .....12

High Pressure Piston Pumps .....12

**Personal Protective Equipment ... STAY SAFE ..... 13**

Operating Tips .....14

Nozzle Selection .....15

**Nozzle Safety ..... 15**

Operator’s Hand Signals.....16

Accident Reporting.....16

Emergency Medical Information.....16

Service Record.....17

Frost protection .....17

Maintenance, Service and Spares .....18

Troubleshooting Guide.....18

Replacement Parts .....19

Pump Kits .....20

Warnings .....24

Jetter Daily Checklist .....24

Six Monthly Regular Service.....24

## THANK YOU FOR PURCHASING AN AUSSIE COBRA DRAIN CLEANING JETTER

We want you to get the best results from your new machine and operate it safely. This manual contains information on how to do that, please read it carefully before operating the machine.

Please note that drain and sewer cleaning procedures must be followed carefully. If not it can result in severe injury or even death. Appropriate safety clothing and equipment must be used at all times.

The Aussie Cobra series of drain cleaning Jetters use water at high pressure to clear blockages such as grease, sediment and tree roots from drains. The pressure is generated by restricting the flow of water with a nozzle at the end of an extremely flexible sewer hose.

The nozzle has reverse facing high pressure jets of water that propel the hose along the drain clearing blockages and flushing away the debris.

## SPECIFICATIONS

	Cobra A	King Cobra A (Honda)	King Cobra (Honda)	King Cobra (Vanguard)	Python
Safety Classification	Class A	Class A	Class B	Class B	Class B
Drain size	Up to 6"	Up to 7"	Up to 8"	Up to 8"	Up to 9"
Max water delivery	20 lpm	16 lpm	23 lpm	25 lpm	31 lpm
Max Output pressure	4,000 psi	5,000 psi	5,000 psi	5,000 psi	4,300 psi (4,200 psi Honda iGX)
Engine model	Honda GX630	Honda GX630	Honda GX690	Vanguard 27HP	Vanguard 35HP, Honda iGX800, or Kohler diesel
Fuel	Petrol	Petrol	Petrol	Petrol	Diesel
Cooling	Air	Air	Air	Air	Air
Starting system	Electric start	Electric start	Electric start	Electric start	Electric start
Battery	Dry cell	Dry cell	Dry cell	Dry cell	Dry cell
Bertolini Pump	TTL 2028	KTL 1635	KTL 2035	RAL 2535-P	RAS 4482-P
RPM	1450	1450	1450	1450	1450
Hose supplied	60m x 1/4"	60m x 1/4"	60m x 1/4"	60m x 1/4"	60m x 3/8"
Drain Cleaning Nozzles Supplied	Aussie Jetters Nozzle Box	Aussie Jetters Nozzle Box (KC)	Aussie Jetters Nozzle Box	Aussie Jetters Nozzle Box	Aussie Jetters Nozzle Box + two high flow nozzles



## WARRANTY COVERAGE

**Aussie Pumps is proud to use engines from the world's best engine manufacturers.** These engines carry a full international warranty provided by these manufacturers and is backed up by their extensive dealer network.

### Engine

Please refer to the engine manual for the full terms and conditions of the engine warranty and your responsibilities of ownership. If a problem should arise or if you have any questions about your engine, consult an authorised service agent. Check online for your nearest engine dealer.

### Pump

The **Bertolini pump** fitted to the drain cleaning Jetter has a **four year warranty**, providing it is serviced by an authorised service agent every six months. Keep your receipt as proof of purchase and all service receipts to maintain this warranty. This guarantee is invalid if the product is found to have been abused in any way, or not used for the purpose for which it was intended.



### Battery

The battery fitted to your Jetter is an AGM (Absorbed Glass Mat) dry cell battery with a full one year warranty from the battery manufacturer. For service contact your DEKA Battery agent via Ryde Federal Batteries (02) 9879 5422. Please read the battery safety information to prevent possible injuries. **Please ensure battery is maintained otherwise warranty is void.**

### Jetter

The **Aussie Drain Cleaning Jetter** has a one year warranty from date of purchase. This warranty covers any defect which occurs due to faulty workmanship or material under normal use. This warranty specifically excludes the following:

- Damage resulting from debris or mineral deposits contained within the water supply to the machine.
- Leaking hoses when the outer cover of the hose has been abraded or the hose has been kinked.
- Damage to o-rings and valves, etc. caused by the use of cleaning chemicals or compounds.

- Replacement of parts damaged due to fair wear and tear.
- Misuse, negligence, alteration, accident or breakage.
- Failure of the machine due to lack of normal maintenance services (The owner is responsible for the performance of regular maintenance services, as specified in the Operator's Manual).
- Damage and/or progressive damage caused by the failure to inform Australian Pump Industries Pty Ltd, or the closest Authorised Australian Pump Agent or Distributor, within seven days of the defect becoming apparent.
- Repair or modification by an unauthorised service person.

**Routine maintenance is the owner's responsibility.** Failure to maintain the machine in line with the services outlined on the back page will invalidate warranty. High pressure accessories carry a 3 month warranty.

Australian Pump Industries Pty Ltd specifically excludes from warranty responsibility any consequential loss or damage including on-site servicing, loss of time, loss of use of the machine, hire costs of a replacement machine or inconvenience.

Where possible return faulty goods to the place of purchase. No products can be returned to us without prior permission. The reason for return must be clearly stated.

N.B. Warranty is not transferable to third parties in the event of sale of the machine within the warranty period. Please note that any parts used in warranty repairs are guaranteed for a period limited by the original warranty of the parent product.

Our goods come with guarantees that cannot be excluded under the Australian Consumer Law. You are entitled to a replacement or refund for a major failure and for compensation for any other reasonably foreseeable loss or damage. You are also entitled to have the goods repaired or replaced if the goods fail to be of acceptable quality and the failure does not amount to a major failure.

The benefits under the Aussie Pump warranty are in addition to other rights under Australian Consumer Law.



## SAFETY PRECAUTIONS

Everyone who uses a high pressure Jetter must be competent to do so.

1. **Never** direct the spray jet at any person or animal.
2. **Never** direct the spray jet at any surface that may contain asbestos.
3. **Do not** operate the Jetter with a nozzle attached to the hose, with the end of the hose outside the drain. The hose will whip out of control and could cause injury.
4. **Never hold a finger** over the high pressure nozzle. Skin can be penetrated by high pressure water jets.
5. **Never** direct the spray jet at the machine itself or any electrical equipment.
6. After use, **release the pressure** in the high pressure hose by operating the hose reel ball valve (or gun trigger if using gun/lance).
7. **When not in use, always switch off the engine, depressurise all hoses and disconnect from water supply.**
8. Certain engine components become **very hot** when in use, e.g. exhaust muffler and cylinder head. Switch off the engine and **ALLOW TO COOL** before touching or refuelling.
9. **Do not attempt** any mechanical repair. If you have a problem with your machine contact your local dealer or Aussie Pumps service division, phone 02 8865 3500.
10. **Never supply any liquid** other than clean water to the water inlet.
11. **Never pull the high pressure hose** if it has formed kinks or nooses. Never pull the hose over sharp objects and do not allow the hose to be driven over. A damaged hose must be professionally repaired or replaced. Visually check hoses prior to each use.
12. **Do not join sewer hoses** together; couplings may fail or get jammed in drains.
13. **Use in a well-ventilated area.**
14. **Ensure unit is level during operation;** engine damage could result due to low oil level.

15. **Do not attempt to disconnect any hose or coupling with pressure still in the hose.**
16. **Do not operate** the machine whilst standing on ladders; use a platform tower or scaffolding.
17. **Prevent Jetter from moving** during operation by using chocks behind the wheels.
18. **Use safety goggles** when using the machine, particularly with the sand blasting attachment, or any application where loose particles of stone or grit, etc, may be blown around by the high pressure spray.
19. **Stay alert and pay attention** to what you are doing and the machine you are operating. Do not use Jetter while you are tired or under the influence of drugs, alcohol or medication that can impair judgement.

## WORK AREA SAFETY ... MINIMISE HAZARDS

Keep work area clean and well lit.

Set up the Jetter and work area in such a way as to reduce the risk of injury from high pressure water, chemical burns, infections, carbon monoxide and other causes.

**Mark off the area with barriers** if necessary to keep bystanders, passing traffic and non-essential personnel away.

Check for flammable or poisonous liquids, vapours and dust that may ignite. Do not operate Jetter until the area has been made safe.

Check the condition of the drains before starting to jet. Drains that are in good condition will not be damaged by the jetting process. Poorly maintained or constructed drains may result in jetting being less effective and could lead to further damage to the drain.

## RISK ASSESSMENT

**COMPLETE A RISK ASSESSMENT OF THE SITE & JOB BEFORE YOU START.**

See risk assessment checklist for jetting equipment page 3.



## STAY SAFE

### Safety Clothing

All persons operating the unit must wear protective clothing such as safety goggles, face shields, gloves, overalls or raincoat, steel cap boots and ear protection equipment as appropriate. Refer to page 13 for details.

### Engine Hazards

Engines emit toxic poisonous carbon monoxide gas which is a colourless, odourless gas. Do not run the Jetter in an enclosed area.

Petrol is extremely volatile and explosive under certain conditions. Please note the following:

- Turn off engine and allow to cool before refuelling.
- Refuelling of the unit must be done in a careful manner. Do not overfill the fuel tank. Use suitable equipment for refuelling (suitable containers and funnels). Once the unit is refuelled, please ensure that the fuel tank lid is closed properly and securely.

Parts of the engine will get hot when it is running. These hot surfaces can cause burns and fire. Keep body parts away from hot areas and be aware that these parts will take time to cool down. Refer page 3.

### Jetter Warning

Before starting up your Aussie Cobra drain cleaning Jetter, ensure that you have read and fully understood this manual. Also watch the hand over video by scanning QR code on cover page.

**Note: Certification of the operator is mandatory for Class B machines ... refer to AS/NZS4233.1.**

**The sewer hose has been marked** at 1m, 2m and 3m from end of the hose. This ensures that the operator is aware that he is getting near to the end of his sewer hose as it is being removed from the drain or sewer line. Before removing the last two metres of sewer hose from the sewer line or drain pipe, water pressure to the nozzle **must be shut off**. Severe injury or death may occur if this procedure is not followed.

### Wash Down Operation

Whilst using your Jetter for wash down with the gun/lance, do not spray any persons or animal. Severe injury or death may result if this procedure is not followed.

### Bacteria Warning

Sewer lines and drainpipes can carry bacteria and other dangerous micro-organisms which may be infectious. These may cause severe illness or death if exposed to person's mouth, nose, ears, eyes, hands or open cuts and abrasions. To protect the operator against these infectious micro-organisms or bacteria, it is imperative that arms, hands and other areas of the body must be washed after working with sewer lines, with hot soapy water. Refer page 3.

**Do not smoke or eat** while using the Jetter as this may lead to the transfer of dangerous micro-organisms into the body.

### Frost Protection

Do not use the Jetter if there is a chance that ice has formed inside the hose or pump. See page 17.

## UTE OR TRAILER MOUNTING OF JETTER

**Aussie Trolley mounted Jettors** must be secured during transit. Special care must be taken to ensure frame is not stressed when using tie-downs to prevent frame distortion.



1. **Do not operate Jetter** while the unit is tied down for transportation as frame damage can result.
2. If the Jetter is to be used while secured on the ute it is **strongly recommend** that it is permanently mounted using an Aussie Cobra Loc bracket. Note the wheels are removed and the bracket holds the Jetter by the axles on the frame.

**Position Jetter on ute tray between rear axle and headboard to minimise vibrations during transit.**

Contact your local distributor for more information.



## ACCESSORY IDENTIFICATION

The Aussie Jetter is equipped with the following jetting accessories:

- **Aussie steel hose reel rated to 6,000 psi**
- **60 metres of 5,000 psi** rated 1/4" or 3/8" ID R8 sewer cleaning hose with quick fit snap on connection on outlet.  
(s/code 1/4" AHOSE RF8-60M  
3/8" AHOSER8 3/8 60M)
- **Aussie Jetter Nozzle box** (s/code AD NOZZLE BOX)



- Penetrator nozzle with 3 rear jets & 1 forward jet
- Negotiator nozzle with 6 rear jets & 1 forward jet
- Aussie Root Mulcher rear turbine root cutter
- Compressor nozzle
- Spare snap on coupler
- Tip cleaner & allen key for nozzle disassembly
- **Safety plate** ... used to prevent jetting nozzle from accidentally exiting the drain under pressure. (s/code AD MSP)



- **Heavy duty wash down gun** with 900mm stainless steel lance & high pressure nozzle



Hose restraint

- **Hose restraint** ... (supplied as standard with all Aussie Class B Jettors) Protects operator in case of hose or hose fittings failure, use mandated by safety standard AS/NZS4233.1 (s/code: AD HRSS8)

**Please check that all accessories are supplied carefully as claims will not be accepted seven (7) days after purchase date.**



### Jetting Essential Accessories Checklist

Accessories that may be required for **Class B Jetter operation** as per safety standard AS/NZS4233.1 subject to your own risk assessment.

#### STANDARD WITH AUSSIE CLASS B JETTERS

- **Safety plate** ... used to prevent jetting nozzle from accidentally exiting the drain under pressure.
- **Hose restraint** ... Protects operator in case of hose or hose fittings failure.

#### SOLD SEPERATELY ...

- **Foot valve** (hold & activate device) (s/code: AST350-2605-KIT)
- **Safety gloves** ... rated to 500 BAR (s/code: ATSTP5600025/11)



#### Optional Accessories .... MAKING JETTING FASTER!

- STRONGLY RECOMMENDED: Aussie Viper Mini reel**, mobile hose reel fitted with lightweight sewer hose. Allows remote control of Jetter for safer operation. (s/code: AMINIREEL/WHOSE)
- Super worm hose**, 1/8" super flexible hose, ideal for small drains & tight bends (40mm or smaller). Complete with compressor nozzle and quick fit tail. (s/code: AHOSER8 1/8 15M)
- Aussie Cobra Loc** bracket to secure the Jetter to ute or trailer (s/code: ACRADLECOBRA)





## PREPARATION FOR USE

### Pump / Gearbox / Engine

1. Check the oil in the pump, gearbox & engine.  
 Note there are separate oil reservoirs for the pump, gearbox and engine.  
 With the machine on a level surface, the pump oil level should cover the red dot in the oil level sight glass on the side of the pump/gearbox.  
 If necessary, top up with **SAE 75W-90** oil (non-foaming type). Do not mix different grades of oil as this may affect the machine's performance. If alternative oil is used, first empty out oil by unscrewing drain plug in bottom of machine.
2. Ensure breather / plug is fitted to pump (red).
3. Note that the gearbox has a separate oil reservoir. Gearbox oil is **SAE 75W-90** gear oil.
4. Check engine oil level. Refer to engine manufacturer's separate handbook.

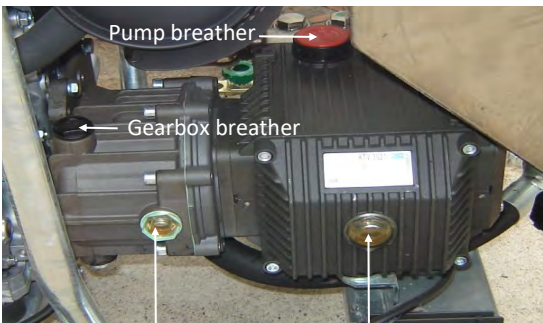

Gearbox sight glass      Pump sight glass

## START UP PROCEDURE

### Water Supply Hose

1. Use a good quality garden hose of ¾" (19mm) diameter minimum (not supplied).
2. Fasten one end of the hose to the inlet hose connector fitted to inlet on break tank and the other to the tap. Ensure the supply hose has been flushed to remove any obstructions before attaching to the water tank.
3. The break tank is fitted with a low water cut out. The engine will not run if the water level drops below this point.
4. To prevent the ingress of foreign bodies into the pump the Jetter is fitted with an Aussie Pump Saver Filter. Check filter regularly and rinse element. (See *Jetter Daily Checklist* on page 24)

Ensure break tank is drained, by removing filter assembly, before transit.



### OIL PROPERTIES

Oil loses its lubricity over time. Change pump & gearbox oil **every 6 months** during regular service.  
**FAILURE TO CARRY OUT REGULAR MAINTENANCE VOIDS WARRANTY!**

### AVOID FRAME DAMAGE

**Do not operate** your Aussie Jetter while the unit is tied down for transport. Frame damage can result through restricted vibration. Use an **Aussie Cobra Loc** for best protection.

### BATTERY MAINTENANCE

Aussie Drain Cleaning Jettters are fitted with an AGM (Absorbed Glass Mat) dry cell battery. It may be necessary to run the Jetter for at least 20 mins to recharge the battery as required.  
 If the battery is flat it may be recharged using a recharger. Contact a battery specialist for further assistance.

### EXCESSIVE BYPASS

Switch machine off within 2 minutes of ceasing operation as excessive bypass can cause heat build-up in pump and subsequent damage.  
**EXCESSIVE BYPASS RUNNING VOIDS WARRANTY!**

**DEPRESSURISE ALL HOSES BEFORE LEAVING UNIT UNATTENDED.**





## OPERATION AS A DRAIN CLEANING JETTER

1. Trolley mounted Jetters should be **chocked** to prevent movement during operation.
2. **Turn on water supply.** Note: Tap should be fully on.
3. **Ensure break tank is full** and float valve has shut off.
4. **Engage battery isolator** and check emergency stop button is reset (if fitted).

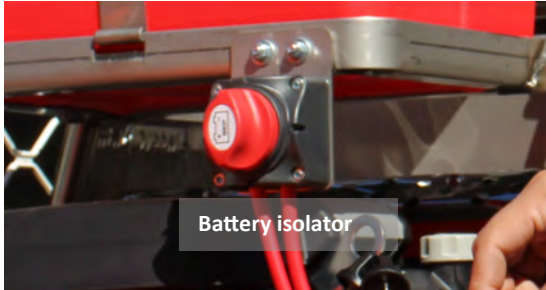

5. **Open breather vent** in fuel tank cap and fuel tap.



6. The ball valve on the mounted hose reel acts like the trigger on a high pressure spray gun. Ensure it is in the **OPEN** position before starting the engine.



7. **WARNING:** Ensure **no nozzle** is fitted to the hose, it must be open flow, before turning on the engine!
8. **Hold open ended hose in hand,** point downwards and start the engine. Ensure engine choke is fully open and turn the key or pull the starter rope to start engine. (Refer to engine manual for more details). Adjust throttle speed as required.
9. Once the engine is started, **close the ball valve.**
10. **Run out a sufficient** length of sewer hose from the hose reel. Do not fit nozzle yet.
11. **Push at least 3 metres** of sewer hose through the hole in the centre of safety plate. **NOTE: First remove hose restraint from hose if fitted** (see page 8).
12. Now select appropriate drain cleaning nozzle and attach to end of sewer hose. Ensure it is **fully snapped into position.**
13. **Place at least 2 metres** of hose down the drain, use hose markings as a guide. **Cover the entrance to the**



**drain with the safety plate.**

14. **Turn on ball valve** to activate high pressure jet to nozzle.
15. **Ease the hose down the drain.** Twist the hose to aid the nozzle in negotiating bends and turns. The nozzle will create a gentle pulling action on the hose. If it becomes stuck a sharp tug will usually free it.
16. For more jetting tips check out page 14.

### Changing Nozzles ...

#### ALWAYS WEAR PROTECTIVE GLOVES

1. Turn off the ball valve before removing the hose out of the drain.
2. Change over the nozzle as required, ensuring the replacement nozzle is fully snapped into position.

**WARNING:** When removing hose from drain you must turn off the ball valve before or as the 2 metre mark on the hose appears. **The hose has been marked for your safety and these marks must be renewed as required.**



### Turning off the Jetter

1. **Remove all but the last 2 metres** of sewer hose from the drain.
2. **Turn off the ball valve.**
3. **De-throttle the engine** and turn off.
4. **Release the pressure** still in the hose by opening the ball valve and wait until hose relaxes.
5. **Pull out the remaining hose** out of the drain and remove the nozzle.
6. Ensure the engine key is turned to the off position and the fuel tap is off.
7. **Isolate the battery.**
8. Disconnect the supply hose & drain water tank.
9. Clean & stow sewer hose and nozzle. Connect end of hose to coupler on the frame.



## AUSSIE VIPER MINI REEL OPERATION (STRONGLY RECOMMENDED OPTIONAL EXTRA)

Using a **Aussie Viper Mini Reel** gives the user the option of remotely controlling the Jetter at the drain entrance.

1. **With no nozzle or mini reel attached**, hold the end of the Jetter sewer hose and start the engine. Turn off the ball valve on the Jetter hose reel.
2. Run out sufficient sewer hose from Jetter reel to reach drain access point.
3. **Slip the hose restraint over the end of the Jetter sewer hose (Class B Jetters only).**



4. Connect the extended Jetter sewer hose to the inlet on the **Viper Mini Reel** and secure the hose restraint.
5. **Ensure the ball valve on the Mini Reel is closed.**
6. Run out a sufficient length of sewer hose from the Viper Mini Reel.
7. Push at least 3 metres of sewer hose through the hole in the centre of safety plate.
8. Attach selected drain cleaning nozzle to end of sewer hose and ensure it is **fully snapped into position.**
9. **Place at least 2 metres** of hose down the drain, use hose markings as a guide. Cover the entrance to the drain with the safety plate.
10. **Turn on ball valve** on the Jetter, and then turn on the ball valve on the **Viper Mini Reel** to activate the high pressure jet to the nozzle.
11. **Ease the hose down the drain.** Twist the hose to aid the nozzle in negotiating bends and turns. The nozzle

will create a gentle pulling action on the hose. If it becomes stuck a sharp tug will usually free it.

12. **NOTE** the ball valve on the **Viper Mini Reel** controls the pressure to the nozzle, the ball valve on the Jetter controls the pressure in the sewer hose to the Mini Reel.
13. Pressure in the Jetter sewer hose must be released before disconnecting the **Viper Mini Reel.**



## EMERGENCY STOP BUTTON



All Class B Jetters are fitted with a mandatory emergency stop, as per safety standard AS/NZS4233.1.

This should only be used in an emergency.

Australian Pump recommends de-throttling the engine and running with no load before shutting off the engine by turning the key.

If the emergency stop button has been used, it will need to be reset before the engine will start again. To reset, turn the button clockwise.

**WARNING** Immediately after activating the E-stop turn the ignition key to the OFF position. **Failure to do so could result in a flat battery and shortened battery life.**



## OPERATION AS A PRESSURE CLEANER

1. **Turn on water supply.**  
Note: Tap should be left fully open.
2. **Ensure break tank is full** and float valve has shut off.
3. **Slip the hose restraint** over the end of the sewer hose (Class B Jetters only)



4. **Fit the gun/lance assembly** to the end of the sewer hose. Slide

hose restraint to end of hose and connect to gun.

5. **Open the ball valve** on Jetter hose reel.
6. **Hold gun trigger open**, ensure firm footing and brace for pressure.
7. **Turn on engine** and release trigger on gun. (Refer to engine manual for more details).
8. **Check there are no leaks** in the line connections. All leaks must be fixed before using the Jetter.
9. When using gun and lance, pressure begins when the gun trigger is squeezed.

### Turning off the Pressure Washer

1. **De-throttle the engine** and turn off.
2. **Release the pressure** still in the hose using the gun trigger.
3. **Ensure the engine key** is turned to the off position and the fuel tap is off.
4. Isolate the battery.
5. Disconnect the supply hose.

**NOTE the red safety lock on the trigger must be engaged when gun is not in use.**

## ASP KIT ... AUSSIE SAFETY PROTECTION

**DO NOT** run machine on bypass for more than 2 minutes.

**AUSSIE SAFETY VALVE:** This device “blows off” excess pressure if unloader has been tampered with, thus protecting the pump.

Do not tamper with pre-set unloader and safety valve. **(This will void your warranty.)**

## HIGH PRESSURE PISTON PUMPS

Your high pressure Bertolini pumping system is the heart of your drain cleaning Jetter. The Pump has been specially designed to be used with cold water (max 74°C) for pipe water jetting and high pressure wash down applications. Your high pressure Bertolini piston pump is designed to move a certain amount of water per revolution by its three solid ceramic pistons.

High pressure is created once the pump outlet is restricted with a nozzle. All high pressure outlet connections, hosing and equipment is rated over and above the maximum operating pressures of the pump.

Do not adjust any valves on your pump; tampering will void warranty. For any malfunction of the high pressure pumping system, please contact API or authorised Service Agent.

Because of safety/danger hazards with high pressure systems, only use approved genuine Aussie high pressure hoses and components when replacing or repairing your Aussie Cobra drain cleaning Jetter. For guidance on this, please contact API or the Distributor you purchased the unit from.

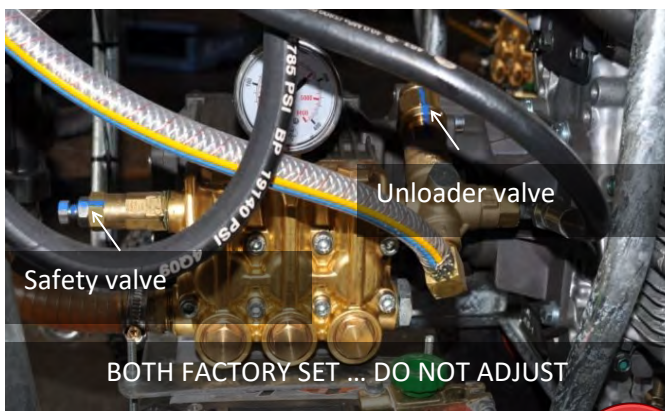

**ALTERING THE HIGH PRESSURE PUMPING SYSTEM MAY RESULT IN SEVERE INJURY OR DEATH.**

Warranty will be void if any high pressure equipment has been altered by unauthorised persons. Over-speeding or over-pressurising of pumping system can be very dangerous and severely reduce the life of your Aussie Cobra Drain Cleaning Jetter and may result in injury or death.

## PERSONAL PROTECTIVE EQUIPMENT ... STAY SAFE



Appropriate personal protective equipment should be worn where:

- hazards cannot be otherwise prevented or suitably controlled, e.g. by engineering or administration controls, total enclosure or substitution; and/or
- complete protection is essential, e.g. in some occupational environments with uncertain levels of hazards.

The provision and use of personal protective equipment does not reduce or replace the need for proper Occupational Health and Safety prevention measures, such as engineering or administrative controls to be undertaken. Recommendations of such preventative measures should always be fully explored before considering issue of personal protective equipment. Where personal protective equipment is issued, instruction and training should be provided regarding its correct use and maintenance.

### ■ Head Protection.

Where appropriate suitable head protection complying with AS/NZS 1801 should be worn.

### ■ Eye Protection.

Eye protection complying with AS/NZS 1337 (adequate for the purpose and of adequate fit on the person) should be worn at all times when in the vicinity of water blasting operations. Where liquid is liable to cause eye damage, full visor and goggles are recommended.

### ■ Body Protection.

All persons should wear suitable waterproof clothing complying with AS/NZS 3765.1 (or AS/NZS 3765.2 if working with hazardous chemicals), having regard to the type of work being undertaken. Liquid or chemical-resistant suits should be worn where there is an assessed risk to health or of injury that can be prevented by such equipment.

### ■ Hand Protection.

Adequate hand protection complying with the recommendation/s of AS/NZS 2161.2, AS/NZS 2161.3 or AS/NZS 2161.5 should be worn when there is an assessed risk of injury that can be prevented by such equipment.

### ■ Foot Protection.

All persons should wear appropriate occupational protective footwear complying with AS/NZS 2210.2. A lower leg guard should be used by water blasting operators where it is assessed that the risk of foot injury could be prevented by such equipment. AS/NZS 2210.1 provides guidance for the selection of footwear.

### ■ Hearing Protection.

Suitable hearing protection complying with AS/NZS 1270 should be worn at all times when the noise levels exceed limits set by regulatory authorities.

### Comfort, function & Safety ... at an affordable price

Aussie Pumps supply a full range of personal safety protection gear rated to 500 BAR (7,300 psi)... call for details or check online ... [www.aussiepumps.com.au](http://www.aussiepumps.com.au)



# AUSSIE SAFE JETTING

## OPERATING TIPS

These are some of the tips and techniques that have been tried and tested over the years to make jetting easier.

- Select your hose diameter according to the size of drain you are cleaning.

Jetter Hose Selection	
Pipe size	Sewer hose size
1"-2"	1/8"
2"- 4"	3/16"
2"- 6"	1/4"
5"- 10"	3/8"

- Always use the safety plate. It will protect your sewer hose against damage from sharp edges and rough surfaces at the entrance to the drain. More damage is done to a hose on the entry and exit point of the drain than anywhere else.

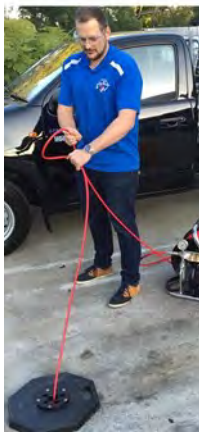

The safety plate also prevents the jetting nozzle accidentally exiting the drain while under pressure.

- Start your jetting with a long nozzle like the Predator or for smaller drains the Compressor.
- For really tight bends remove the quick coupler from the hose and cowling from the nozzle and connect the head directly to the hose.
- Twist your jet hose to help get it around tight bends and traps.
- Once you have broken through the blockage change to a Root Ranger to clear tree roots from the sides of the drain. When using the Root Ranger Turbine, the hose must be twisted to thoroughly clear the root choke from all sides of the pipe.



- Prevent the Root Ranger turbine from entering side channels by pushing straight through the junction as quickly as possible. Pushing the hose straight without twisting it, will help to keep the turbine on a straight path.
- If your hose becomes jammed, try pulling the hose hard, and then letting it go quickly so it can snap back and loosen itself. Also, try turning the jet off then pull on the hose, then turn jet back on again.
- When accessing a square junction down a shaft, a section of 50mm pipe with an elbow on the end can help direct your nozzle up into the desired location. Alternately you can run your hose through a section of flexible pipe like 50mm ag drain to assist in directing and protecting the sewer hose.

As good as the Aussie Turbo Root Mulcher is it likes to get stuck wherever possible.

- Try running the Root Mulcher straight to the blockage without twisting the hose.
- Leave the hose twist for when you are actually cutting the roots or retrieving the hose from the blockage. This will keep it from heading up any branch drains, toilet pans and PVC capped inspection openings!
- For drains larger than 6" add an extension to the Root Ranger to prevent it from becoming wedged

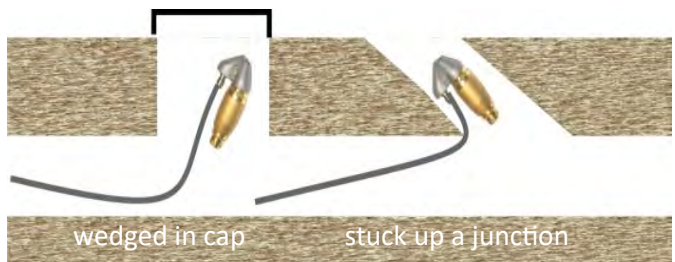

### HOSE WEAR

Aussie supply only top quality, super flexible sewer hose on all Jetters.

The hose must be checked for wear daily and replaced if damaged.

Don't be tempted to use lower grade hose ... STAY SAFE



## NOZZLE SELECTION

There are 3 main types of penetrating nozzles; the Predator, the Negotiator, and the Compressor. These 3 nozzles come in different configuration options – 3 rear 1 forward, 6 rear, 1 forward, and 6 rear only.

**The Predator** is a good starting choice for general drain cleaning. It has a long pointed nose for penetrating deep into a choke and blasting out the debris. (AD P3R1FC)



**The Negotiator** has been designed shorter to get around tight bends and traps. It is a good multi-purpose nozzle for any drain cleaning application. (AD N6R1FC)



**The Compressor** is smaller again, and assists with smaller blockages. A new extension can also be purchased for the Compressor nozzle. (AD C6R1FC)



**The Beaver** has 2 forward firing jets, with 6 reverse thrusting jets. The 2 front jets bore deep into the choke. Ideal for dry chokes. (AD BV6R2FC)



**The Root Rat** is extremely popular. It features 1 front jet with 6 rear jets, 3 behind the tip of the nozzle at 45° and 3 at the rear of the nozzle at 30°, enabling it to quickly penetrate the choke. (AD RR6R1FC)



**The Bullet** is a small, but powerful nozzle used when all else fails. Although it is very effective, it should only be used on difficult chokes. It is so small it has a habit of leaving the drain. (AD B6R1FC)



**The Root Mulcher** is used to clear what the Penetrator nozzles leave behind. It has 1 rear thrust port and an optional front jet. This nozzle will clear just about anything from the drain and is the primary root cutter used by plumbers worldwide. (AD RR8TCF)



**6" Root Mulcher**, this is a larger version of the Root Mulcher with a 1/2" root cutting turbine is used with larger flow Jetters like the Python. (AD LRR8TC)



### LARGER CAPACITY NOZZLES SUPPLIED WITH PYTHON

#### BANDIT (3/8")

**1 front jet & 6 rear jets**  
Designed to enter a blockage quickly and with max thrust. AD BT6R1F10



#### SCREWDRIVER (3/8")

**1 front jet & 6 rear jets**  
Designed to get through the toughest root blockages. AD SD6R1F10



### NOZZLE WEAR

Once drain cleaning nozzles or wash down nozzles have worn, pressure loss will occur. Replacement of nozzles is necessary to maintain constant and maximum efficiency of your Aussie Cobra drain cleaning Jetter.

### NOZZLE SAFETY ... RESPECT THE PRESSURE

- The **Root Mulcher** nozzle must be used in accordance with your own safe work place method statement.
  - **Do not hold** any nozzle while pressurised.
  - **Do not allow** any nozzle to leave the drain while pressurised.
  - **Do not allow** an inexperienced operator use to this nozzle.
  - **Hoses must be conspicuously marked** at a nominal distance of 1 metre from the nozzle to indicate the location of the nozzle.
  - Never use the **Root Mulcher** nozzle in a drain with a diameter larger than 150mm (6") without a fixed extension equalling the diameter of the pipe.
  - **Clean Root Mulcher** nozzle after every use and store in a safe place. Remove the turbine barrel to clear debris regularly. Debris left in the barrel may damage the ceramic insert
  - Ensure nozzle is not damaged or jets obstructed. Dropping the Root Ranger may damage the ceramic insert.
- If struck by the jet of a Root Ranger nozzle, the water will cause massive injuries to human flesh and organs - never lose respect for this nozzle.**
- Ensure a fast shut down procedure is ready while using this nozzle

# AUSSIE SAFE JETTING

## OPERATOR'S HAND SIGNALS

This section provides a set of hand signals for communication when carrying out water jetting operations.

- Pressurise System**  
 Thumb pointing upwards, the rest of the hand closed. From the shoulder height the arm moves up and down.



- Depressurise System.**  
 Form a fist. Move the arm back and forth at shoulder height.



- Raise Pressure.**  
 First finger pointing up, the rest of the hand closed. The hand is moved in a circular motion.



- Lower Pressure.**  
 First finger pointing down, the rest of the hand closed. The hand is moved in a circular motion.



## ACCIDENT REPORTING

- Reporting.**  
 All accidents or injuries, whether resulting in “lost time” or “no lost time” injuries, should be recorded in accordance with the recommendations of AS 1885.1.  
  
 Incidents that result in “near misses” should also be recorded as a means of providing a record of significant incidents that have the potential to result in serious injury at the workplace, so appropriate measures can be implemented to minimise or eliminate these potential hazards.
- Personal Injuries.**  
 In the event that a person is injured by the impact of a water jet, the injury caused may appear insignificant and give little indication of the extent of the injury beneath the skin and the damage to deeper tissues. Although only a small hole may be present, quantities of water may have penetrated the skin and entered the flesh and organs causing serious injury.

- Medical Recommendation.**  
 If an accident occurs where pressurised water penetrates or appears to have penetrated the skin, medical assistance should be sought immediately.
- Immediate First Aid.**  
 Where medical examination is not immediately possible (e.g. in remote situations), appropriate basic first aid measures should be applied and the patient observed closely until medical treatment is available.
- Medical Alert Card.**  
 All operators engaged in commercial and industrial water blasting operations should carry an immediately accessible, waterproof medical alert card. This card should:
  - outline the possible nature of injuries and post-accident infections that can be caused by high pressure water blasting;
  - provide details of immediate first-aid treatment until medical treatment can be arranged; and
  - provide the name or names of medicos (and contact phone numbers) who should be contacted for expert medical advice for the treatment of high pressure water blasting injuries.

In addition, the card may also:

- identify the worker; and
- outline medical information about the worker; e.g. blood type, allergies and conditions, such as asthma.

## EMERGENCY MEDICAL INFORMATION

Immediate hospital attention should be given to personnel who sustain equipment related injuries while operating the system. In such cases, it is vital that medical personnel be apprised of all facts relevant to such injuries.

Therefore, all operating personnel should be provided with waterproof emergency medical tags or cards describing the nature of their work and the possibility of injury inherent in the use of a water blasting device. The tag or card should also bear the following standard notice:

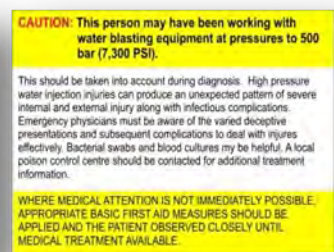





# AUSSIE SAFE JETTING

## MAINTENANCE, SERVICE & SPARES

Your Aussie Eco-Clean drain cleaning Jetter has been designed to give you long and trouble-free service.

If however, you have a problem which cannot be resolved by referring to the Troubleshooting Guide

below, or if you require spare parts or servicing, contact your local dealer (check the website for list; [www.aussiepump.com.au](http://www.aussiepump.com.au)) or call **Aussie Pumps** on **(02) 8865 3500**.

FAULT	CAUSE	REMEDY
Pump running normally but pressure low on installation	Pump sucking air Valves sticking, dirt in valves Unloader valve seat faulty Nozzle incorrectly sized Worn piston packing	Check water supply and possibility of air ingress Check and clean or replace if necessary Check and replace Check and replace Check and replace
Fluctuating pressure	Valves worn Valves blocked Pump sucking air  Worn piston packing	Check and replace Check and clean out if necessary Check water supply and air ingress at joints in suction line Check and replace
Pressure low after period of normal use	Nozzle worn Suction or delivery valves worn Suction or delivery valves blocked Unloader valve seat worn Worn piston packing	Check and replace Check and replace Check and clean if necessary Check and replace if necessary Check and replace if necessary
Pump noisy	Air in suction Broken or weak suction or delivery valve spring Foreign matter in valves Worn bearings Excessive temperature of liquid	Check water supply & connections on suction line Check and replace if necessary Check and clean if necessary Check and replace if necessary Reduce temperature
Presence of water in oil	Oil seal worn High humidity in air Piston packing worn	Check and replace Check and change oil twice as often Check and replace if necessary
Water dripping from under pump	Piston packing worn Plunger retainer worn	Check and replace Check and replace
Oil dripping	Oil seal worn	Check and replace if necessary
Bypass valve switches repeatedly when gun is off	Leaking gun and/or pressure pipe Leaky sleeve Worn out kick-back valve body  Leaky seals	Renew gun, seal pressure pipe Renew sleeve Check and renew as necessary kick-back valve plate and seat Renew seals
Leaky piston rod	Defective o-ring/support ring	Renew piston rod seals and examine surfaces in guide case
Leaky bypass at nominal pressure	Nozzle too small, too much water Worn out bypass valve	Install larger nozzle Examine and renew as necessary
Pressure gauge shows high pressure fluctuations when shutting off gun	Valve set too high above operating pressure Dirty valve	Adjust the unloader at the operating pressure Clean valve (removing lime deposits, etc) Grease parts before installing
Engine will not start	Out of petrol Engine defect Battery flat	Fill tank with petrol Return to engine service agent Use a trickle charge recharging unit only or contact a battery specialist

**REGULARLY CHECK PUMP OIL LEVEL ... DO NOT OVERFILL**

## REPLACEMENT PARTS

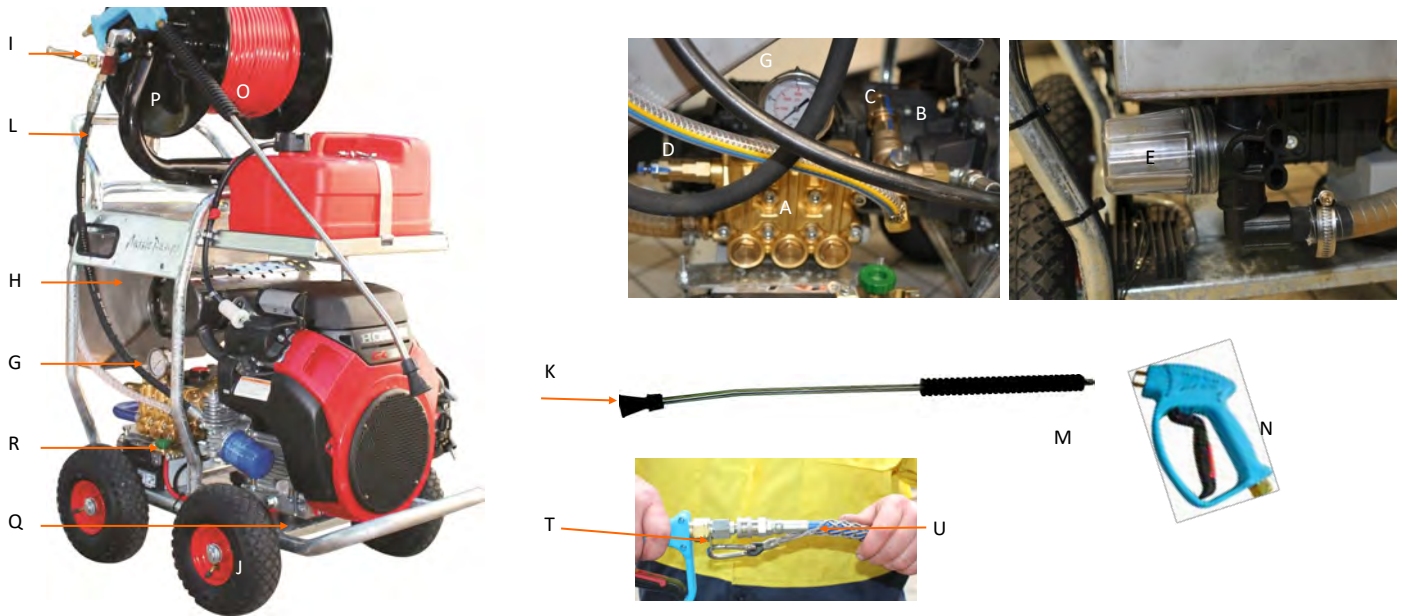

Position	Part No	Description	Cobra A	King Cobra A	King Cobra	Python
<b>Pump</b>						
A	B TTL2028	BERTOLINI PUMP (4,000 PSI, 20 LPM)	x			
	B KTL1635	BERTOLINI PUMP (5,000 PSI, 20 LPM)		x		
	B KTL2035	BERTOLINI PUMP (5,000 PSI, 23 LPM)			x (Honda GX690)	
	B RAL2535-P	BERTOLINI PUMP (5,000 PSI, 25 LPM)			x (Vanguard)	
	B RAS4482-P	BERTOLINI PUMP (4,300 PSI, 31 LPM)				x
<b>Gearboxes</b>						
B	B318870973	GEARBOX (1" PTO)	x			
	B319110973	GEARBOX (1" PTO)		x		
	B319111973	GEARBOX (1 1/8" PTO)			x (Honda GX690)	
	B318880973	GEARBOX (1 1/8" PTO)			x (Vanguard)	x (Vanguard)
	B319219973	GEARBOX (1 1/8" PTO)				x (Honda iGX)
<b>Unloader</b>						
C	BVB350	UNLOADER VALVE (5100 PSI)	x	x	x	x
<b>Safety Valves</b>						
D	M PA60156000	4000 PSI SAFETY VALVE	x			
	M PA60058000	5650 PSI BVS350 SAFETY VALVE		x	x	x
<b>Pump Filter</b>						
E	M8105042	3/4" F LINE STRAINER 80 MESH	x	x	x	
	C73429011	CARTRIDGE FILTER 60 MICRON				x
<b>Fuel Tank</b>						
F	A FUEL TANK COBRA	12 LITRE FUEL TANK	x	x	x	x
<b>Gauge</b>						
G	A GCDR0102	6000 PSI GAUGE	x	x	x	x
<b>Water Tanks</b>						
H	A TANK S COBRA	S/STEEL WATER TANK	x	x	x	x
	M TM22.0001	FLOAT VALVE	x	x	x	x
<b>Ball Valves &amp; Handles</b>						
I	M TM00089501	BALL VALVE 1/4"	x			
	M TM00089502	BALL VALVE 3/8"		x	x	x
<b>Nozzles (in lance)</b>						
K	C915 ___ M	HP NOZZLE (15° ANGLE, TIP SIZE ... refer to table)	045	035	045 (H) / 055 (V)	070
<b>Whip Hose</b>						
L	A R206S166MPX1.6	1.6M WHIP HOSE	x	x	x	x
<b>Lance</b>						
M	C3905.15	900M SS SINGLE LANCE	x	x	x	x
<b>Gun</b>						
N	C GPDG5010	5,000 PSI RATED GUN	x	x	x	x
T	A HRANCHORPLATE	ANCHOR PLATE FOR HOSE RESTRAINT			x	x
<b>Hose &amp; Restraint</b>						
O	A HOSE RF8-60M	HOSE R8 1/4 60M 5000PSI	x	x	x	
	A HOSE8 3/8 60M	HOSE R8 3/8 60M 5000PSI				x
U	A D HRSS8	HOSE RESTRAINT (1/4")			x	
	A D HRSS10	HOSE RESTRAINT (3/8")				x
<b>Hose Reels</b>						
P	A4418SS-REEL	STAINLESS STEEL HOSE REEL 5000 PSI	x	x	x	x
<b>Engine Accessories</b>						
Q	A ENGMOUNTBB300	ENGINE MOUNT (4 NEEDED)	x	x	x	x
R	A BATTERYKEN	DRY CELL BATTERY	x	x	x	x

# AUSSIE SAFE JETTING

## PUMP KITS

### TTL 2028 (Cobra A)

from 07/15  
from serial number 15070568

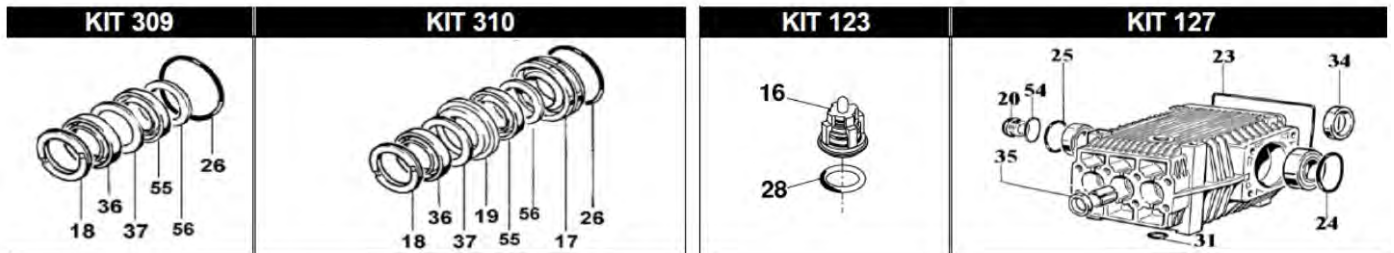
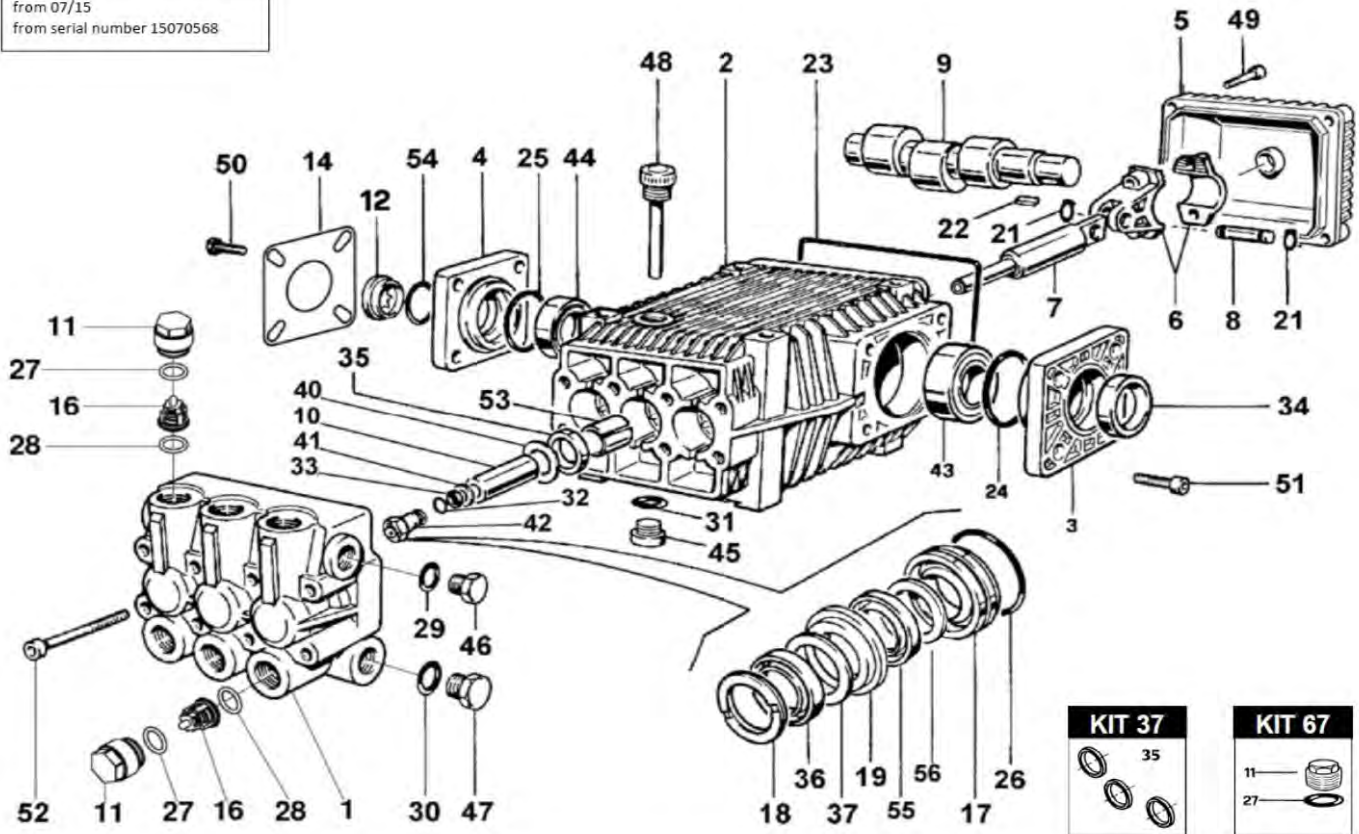

Kit No.	Part No.	Description	Pieces
127	BKIT127	Full Oil seal & Sight Glass kit	10
123	BKIT123	Valve Kit	12
309	BKIT309	Seal Kit Minor	18
310	BKIT310	Seal Kit Major	24
37	BKIT37	Oil Seal Kit	3
67	BKIT67	Valve cap kit	12



Order the right part first time ...  
specify the pump model number when ordering parts.

Full parts breakdowns available online ...  
[www.aussiepumps.com.au](http://www.aussiepumps.com.au)

**Aussie Blaster Fundamentals ...**  
a simple guide to triplex pump  
service & maintenance.

Call for your **FREE** copy.

## PUMP KITS

KTL 1635 (King Cobra A Honda GX630)  
 KTL 2035 (King Cobra Class B Honda GX690)

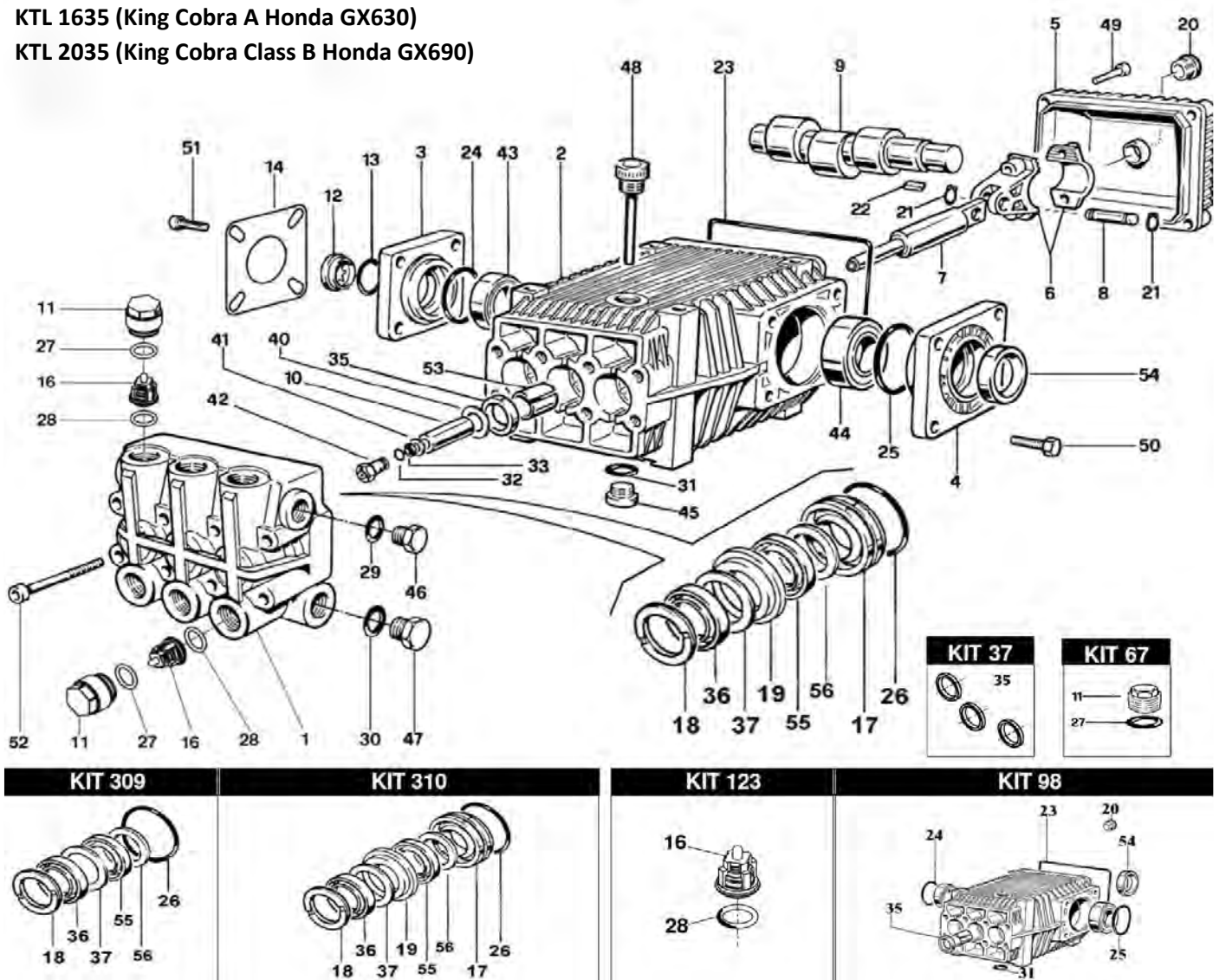

Kit No.	Part No.	Description	Pieces
98	BKIT98	Full Oil seal & Sight Glass kit	9
123	BKIT123	Valve Kit	12
309	BKIT309	Seal Kit Minor	18
310	BKIT310	Seal Kit Major	24
37	BKIT37	Oil Seal Kit	3
67	BKIT67	Valve cap kit	12



Order the right part first time ...  
 specify the pump model number when ordering parts.

Full parts breakdowns available online ...  
[www.aussiepumps.com.au](http://www.aussiepumps.com.au)

**Aussie Blaster Fundamentals** ...  
 a simple guide to triplex pump  
 service & maintenance.

Call for your **FREE** copy.

# AUSSIE SAFE JETTING

## PUMP KITS

### RAL 2535-P (King Cobra Vanguard)

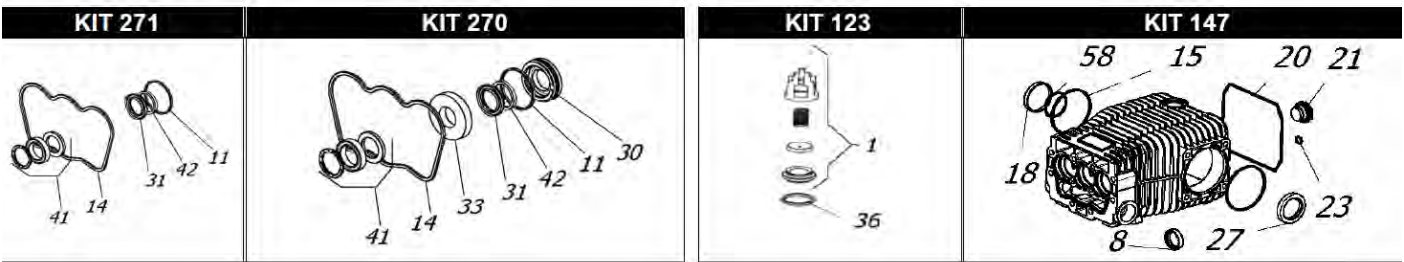
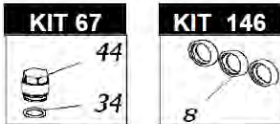
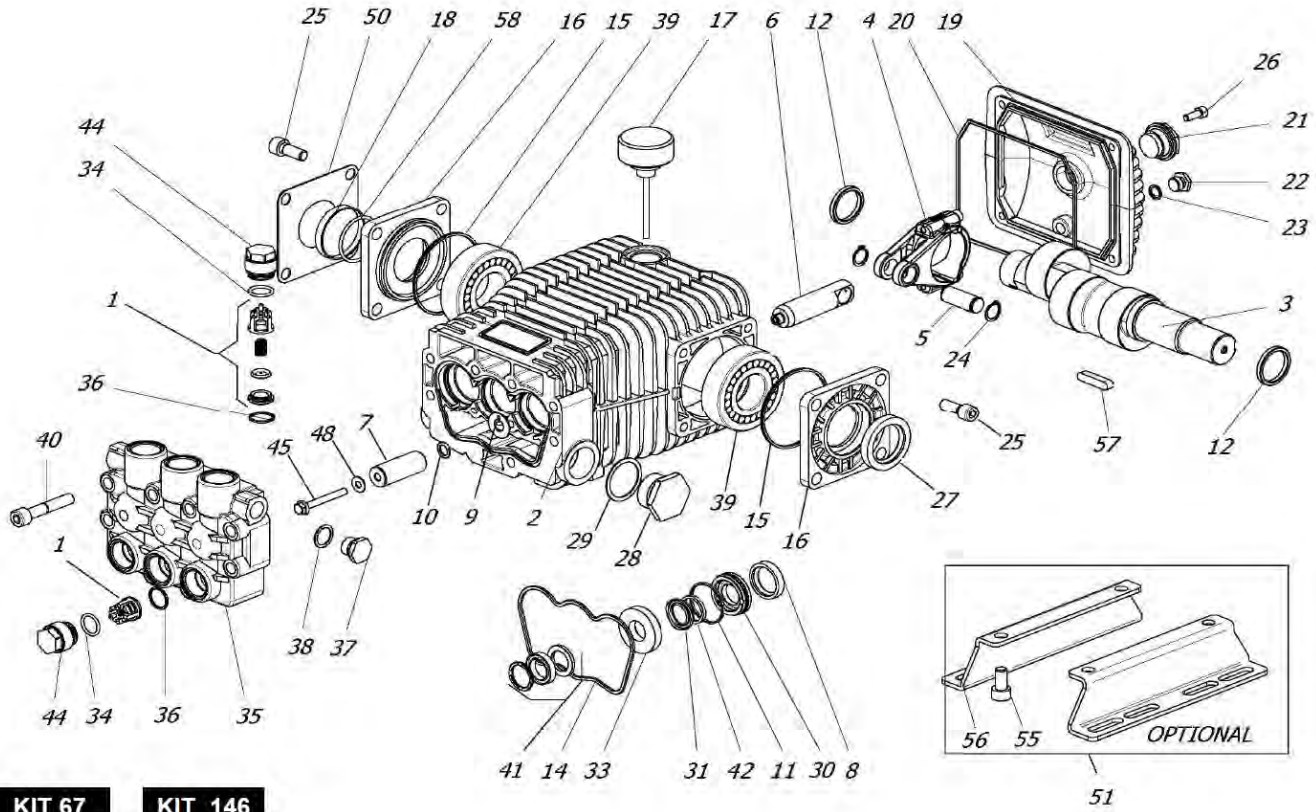

Kit No.	Part No.	Description	Pieces
123	BKIT123	VALVE KIT	12
271	BKIT271	SEAL KIT MINOR	19
270	BKIT270	SEAL KIT MAJOR	25
146	BKIT146	OIL SEAL KIT	3
67	BKIT67	CAP KIT	12
147	BKIT147	O-RING & GLASS KIT	11



Order the right part first time ...  
specify the pump model number when ordering parts.

Full parts breakdowns available online ...  
[www.aussiepumps.com.au](http://www.aussiepumps.com.au)

**Aussie Blaster Fundamentals ...**  
a simple guide to triplex pump  
service & maintenance.

Call for your **FREE** copy.

## PUMP KITS

### RAS 4482-P (Python)

RAS 4482 -P  
(Premium)

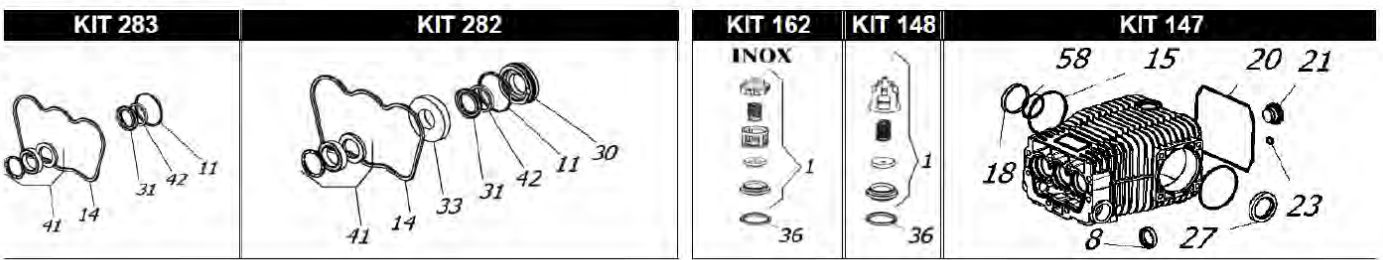
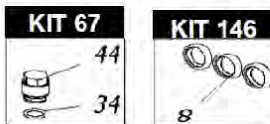
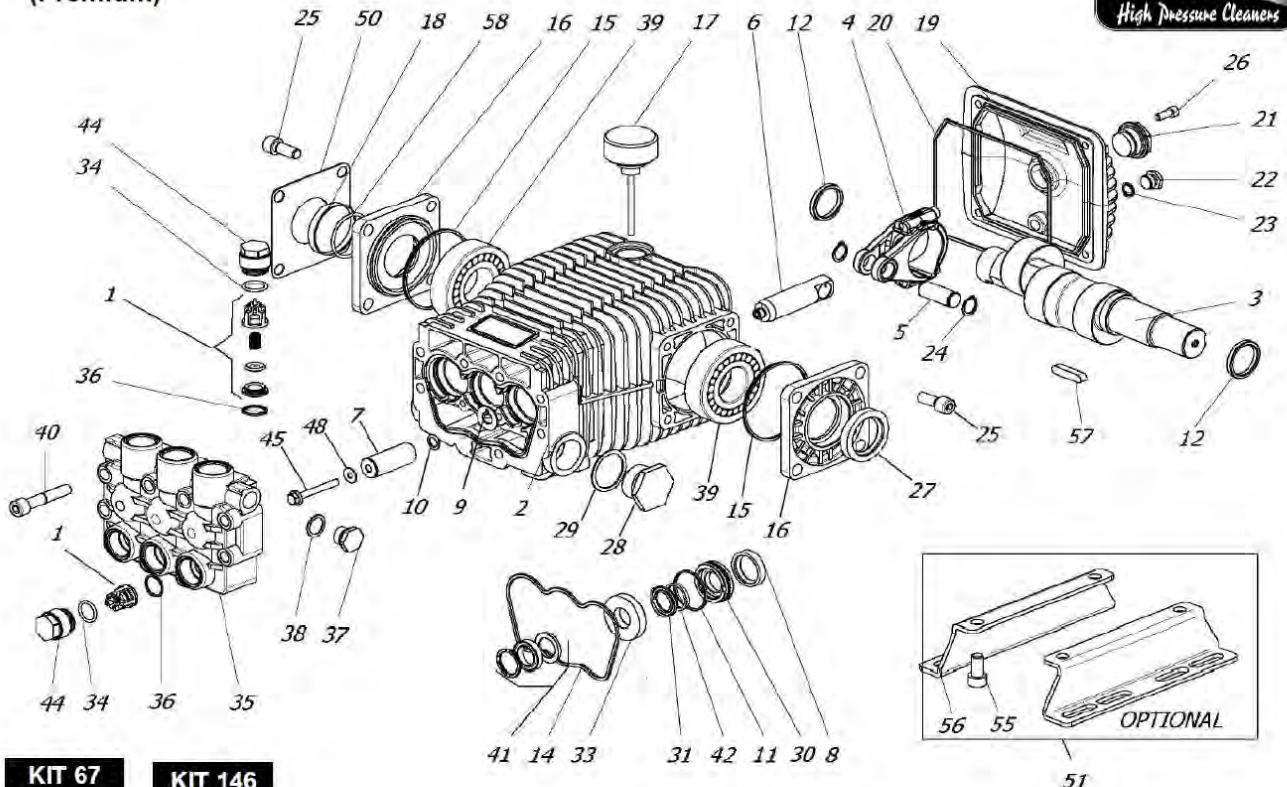

Kit No.	Part No.	Description	Pieces
148	BKIT148	VALVE KIT	12
283	BKIT283	SEAL KIT MINOR	19
282	BKIT282	SEAL KIT MAJOR	25
146	BKIT146	OIL SEAL KIT	3
67	BKIT67	CAP KIT	12
147	BKIT147	O-RING & GLASS KIT	11



Order the right part first time ...  
specify the pump model number when ordering parts.

Full parts breakdowns available online ...  
[www.aussiepumps.com.au](http://www.aussiepumps.com.au)

**Aussie Blaster Fundamentals ...**  
a simple guide to triplex pump  
service & maintenance.

Call for your **FREE** copy.

# AUSSIE SAFE JETTING



## WARNINGS

### ◆ OVER-SPEEDING

Do not operate machine at over engine preset.

Over-speeding can cause serious pump damage and will void warranty.

### ◆ FRAME TIE-DOWNS

Do not operate machine while frame is secured by transit only tie-down points. Frame damage can result.

### ◆ EXCESSIVE BYPASS

Do not run on excessive bypass. Switch machine off within two minutes of ceasing operation as excessive bypass can cause heat build-up in pump and subsequent damage. Excessive bypass running voids warranty. This does not apply to machines fitted with supply tanks.

### ◆ HIGH PRESSURE SETTING

The high pressure pump is factory set to operate at its rated pressure. DO NOT ADJUST. Tampering with the pressure regulator will void warranty and can be DANGEROUS.

### ◆ CHECK NOZZLES & COUPLINGS WEEKLY, clean after each use.

If pressure drops off, check nozzle for wear. Nozzles should be replaced when worn. Using the machine with the incorrect nozzle size or worn nozzle will void warranty and can be DANGEROUS to the operator.

## JETTER DAILY CHECKLIST

1. Check pump & gearbox oil level.
2. Check engine oil level.
3. Check nozzle for wear.
4. Check all high pressure components for leaks, damage, wear or corrosion:
  - a. Gun/Lance
  - b. Jetting hoses & connections
  - c. All fittings
5. Check water filter and clean if necessary.
6. Check unloader & safety valve for leaks.
7. Check the hose markings that mark the last three metres of hose and replace if worn.



## SIX MONTHLY REGULAR SERVICE

All professional machines need to be thoroughly serviced every six months. Use an approved and qualified Aussie service agent. The service involved should include the engine manufacturer's recommendations (see separate Engine Manual) and the following:

1. Change pump & gearbox oil.
2. Change engine oil if required (refer to engine manual for schedule).
3. Check filter for foreign debris.
4. Check unloader & safety valve for leaks.
5. Check all high pressure components, including hoses, for leaks, damage, wear or corrosion. Replace if necessary.
6. Replace nozzles.
7. Check gearbox to engine key for wear. Replace if worn.



**BEWARE** of abrasions on hose and replace if damaged ... **STAY SAFE**

**NB. Damage generated by worn keys is not covered by warranty!**



**LOOK AFTER YOUR MACHINE AND IT WILL LOOK AFTER YOU.**

**AUSTRALIAN PUMP INDUSTRIES**

8 Solent Circuit, Norwest NSW 2153

**(02) 8865 3500** info@aussiepumps.com.au www.aussiepumps.com.au